

Quick Couplings



Quick Couplings



GSIA RC220

Quick Couplings Catalogue

© Intertraco (Italia) S.p.A.

The data reported in this catalogue are not binding. Intertraco (Italia) S.p.A. reserves the right to change specifications without notice.

QUICK RELEASE COUPLINGS CHART BY WORKING PRESSURE AND TEMPERATURE RANGE

series	sizes	interchange	material	valve design	retention	temperature range (°C)
A	1/4" - 2"	ISO 7241-A	steel	poppet	ball locking	-20 / +110
B	1/8" - 1"	ISO 7241-B	steel	poppet	ball locking	-20 / +110
N	1/4" - 1"	ISO 7241-A (size 1/2")	steel	poppet or ball	ball locking	-20 / +110
P	1/2"	ISO 7241-A / ISO 5675	steel	poppet or ball	ball locking	-20 / +110
E	1.1/4" - 3"	 Intertraco design	steel	poppet	ball locking	-20 / +110
S	1/4" - 2"	 Intertraco design	steel	poppet	screw to connect	-20 / +110
J	1/4" - 3/8"	-	steel	ball	screw to connect	-20 / +110
F	1/4" - 2"	ISO 16028 / HTMA (size 3/8")	steel	flat face	ball locking	-20 / +110
FA	1/8" - 1.1/2"	ISO 16028 / HTMA (size 3/8")	steel	flat face	ball locking	-20 / +110
X	1/8" - 1"	ISO 7241-B	A316 inox	poppet	ball locking	-15 / +180
R	1.1/4" - 2.1/2"	 Intertraco design	A316 inox	poppet	ball locking	-20 / +180
Z	1/4" - 2.1/2"	 Intertraco design	A316 inox	poppet	screw to connect	-15 / +180

NOTES:

The indicated performance data are to be considered as guidelines: the actual performance of each couplings depends on size material and selected seal. Please refer to the following pages for more detailed informations.

The correct seal choice must be based on the type of media, working temperature and working pressure. In case of any doubts or special applications, please consult our Technical Dept.

working pressure range															
ø bar	50	100	150	200	250	300	350	400	450	500	550	600	650	700	750
0 / 250	external environment + indoor														
0 / 250	external environment + indoor														
0 / 250	external environment + indoor														
0 / 250	external environment + indoor														
0 / 120	external environment + indoor														
0 / 400	external environment + indoor														
0 / 700	external environment + indoor														
0 / 250	external environment + indoor														
0 / 350	external environment + indoor														
0 / 100	corrosive environment														
0 / 40	corrosive environment														
0 / 400	external environment + marine														

ENVIRONMENT TYPE:

 external environment + indoor

 external environment + marine

 corrosive environment

	product	code	description	page
Quick release coupling	Poppet / Ball valve	A	Ball locking coupling	6
		B	Ball locking coupling	8
		N	Ball locking coupling	10
		P	Ball locking push-pull coupling	13
		E	Ball locking large diameter coupling	17
		S	Screw to connect coupling	19
	Flat face	J	Screw to connect coupling	21
		F	Ball locking flat face coupling	22
	Special application	FA	Ball locking high pressure flat face coupling	24
		X	Ball locking coupling	26
		R	Ball locking coupling	28
	Swivel joint	-	Z	Screw to connect coupling
SJ10			Straight swivel joint	33
	-	SJ90	90° Swivel joint	34
Hydraulic valve	-	CV	In line check valve	35
	-	VPCC	Burst hose valve	36
	-	CVP	Burst hose cartridge valve	37
	-	VRX	Unidirectional flow regulator	38
	-	VRU	Unidirectional flow regulator	39
	-	VRB	Bidirectional flow regulator	40

A



Ball locking coupling

ISO 7241-A

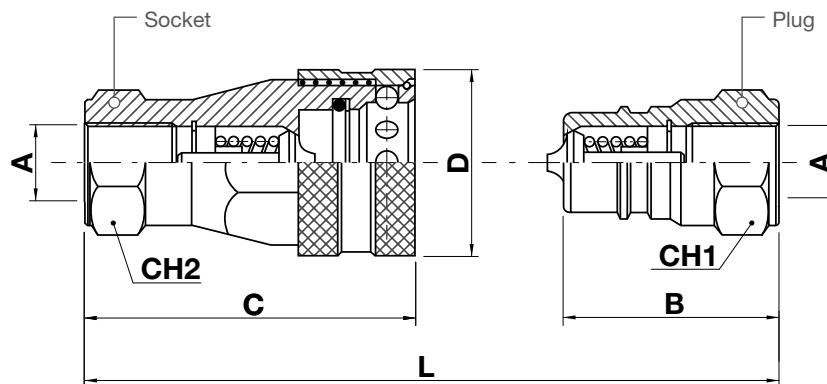

QUICK R. COUPLING

POPPET/BALL VALVE

FLAT FACE
SPECIAL APP.

SWIVEL JOINT

HYDRAULIC VALVE

size	Ø DN		code		Ø A	B		C		Ø D		L		CH1		CH2	
	mm	inch	plug	socket		mm	in	mm	in	mm	in	mm	in	mm	in	mm	in
04	6	1/4"	AM10-04	AF10-04	1/4" BSP	35	1,38	47	1,85	25	0,98	71	2,80	19	0,75	19	0,75
			AM15-04	AF15-04	1/4" NPTF												
			AM18-04	AF18-04	1/4" BSPT												
06	10	3/8"	AM10-06	AF10-06	3/8" BSP	39	1,54	58	2,28	31	1,22	79,5	3,13	22	0,87	24	0,94
			AM15-06	AF15-06	3/8" NPTF												
			AM18-06	AF18-06	3/8" BSPT												
08	12	1/2"	AM10-08	AF10-08	1/2" BSP	46	1,81	67,5	2,66	38	1,50	92	3,62	27	1,06	30	1,18
			AM15-08	AF15-08	1/2" NPTF												
			AM18-08	AF18-08	1/2" BSPT												
12	20	3/4"	AM10-12	AF10-12	3/4" BSP	54	2,13	81	3,19	46	1,81	108	4,25	34	1,34	38	1,50
			AM15-12	AF15-12	3/4" NPTF												
			AM18-12	AF18-12	3/4" BSPT												
16	25	1"	AM10-16	AF10-16	1" BSP	62	2,44	96	3,78	55	2,17	124	4,88	41	1,61	45	1,77
			AM15-16	AF15-16	1" NPTF												
			AM18-16	AF18-16	1" BSPT												
20	32	1.1/4"	AM10-20	AF10-20	1.1/4" BSP	75	2,95	117	4,61	65	2,56	151	5,94	55	2,17	50	1,97
			AM15-20	AF15-20	1.1/4" NPTF												
			AM18-20	AF18-20	1.1/4" BSPT												
24	38	1.1/2"	AM10-24	AF10-24	1.1/2" BSP	85	3,35	135	5,31	80	3,15	171	6,73	60	2,36	60	2,36
			AM15-24	AF15-24	1.1/2" NPTF												
			AM18-24	AF18-24	1.1/2" BSPT												
32	50	2"	AM10-32	AF10-32	2" BSP	100	3,94	160	6,30	100	3,94	201	7,91	75	2,95	75	2,95
			AM15-32	AF15-32	2" NPTF												
			AM18-32	AF18-32	2" BSPT												





MAIN DATA

- Standard material: steel;
- Plugs treated with induction hardening;
- Internal valves in hardened steel;
- Standard seals in nitril rubber;
- Back-up seals in teflon;
- Working temperature with standard nitril seals: -20 °C / +110 °C.

On request

- Special seals: Viton, EPDM, Neoprene;
- Special 1/2" plug and socket for connection in presence of residual back pressure.

PRESSURE DROP GRAPH

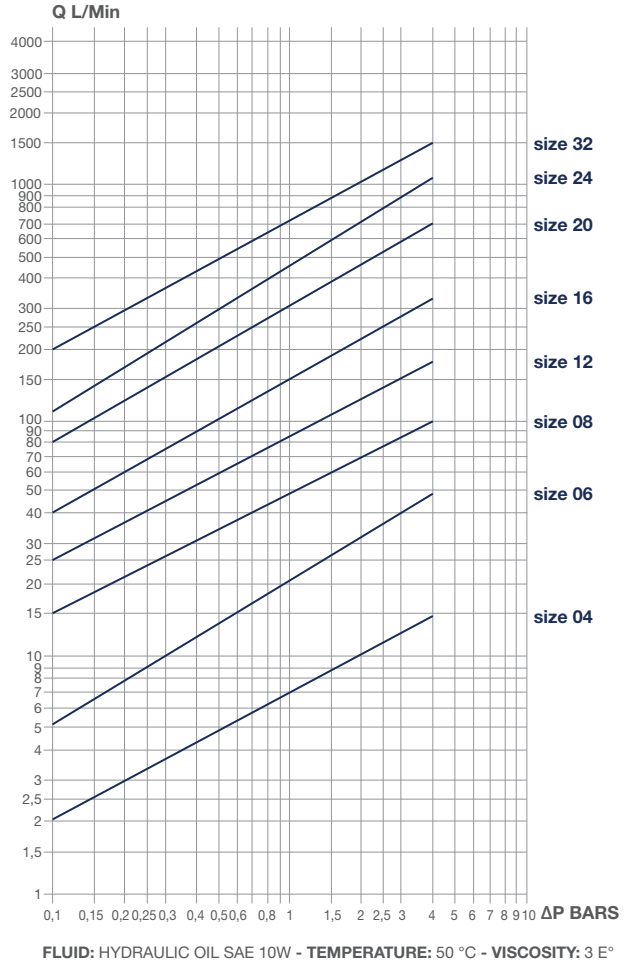

- **QUICK R. COUPLING**
- POPPET/BALL VALVE**
- FLAT FACE
- SPECIAL APP.
- SWIVEL JOINT
- HYDRAULIC VALVE

PERFORMANCES

size	Ø DN		maximum working pressure		burst pressure		weight			
	mm	inch	bar	psi	bar	psi	plug		socket	
							kg	lbs	kg	lbs
04	6	1/4"	350	5075	1400	20300	0,05	0,11	0,08	0,18
06	10	3/8"	315	4567	1260	18270	0,06	0,13	0,15	0,33
08	12	1/2"	250	3625	1000	14500	0,09	0,20	0,27	0,60
12	20	3/4"	250	3625	1000	14500	0,19	0,42	0,47	1,04
16	25	1"	230	3335	920	13340	0,27	0,60	0,72	1,59
20	32	1.1/4"	230	3335	920	13340	0,60	1,32	1,25	2,76
24	38	1.1/2"	190	2755	760	11020	0,90	1,98	2,10	4,63
32	50	2"	130	1885	520	7540	1,45	3,20	4,15	9,15



B



Ball locking coupling

ISO 7241-B

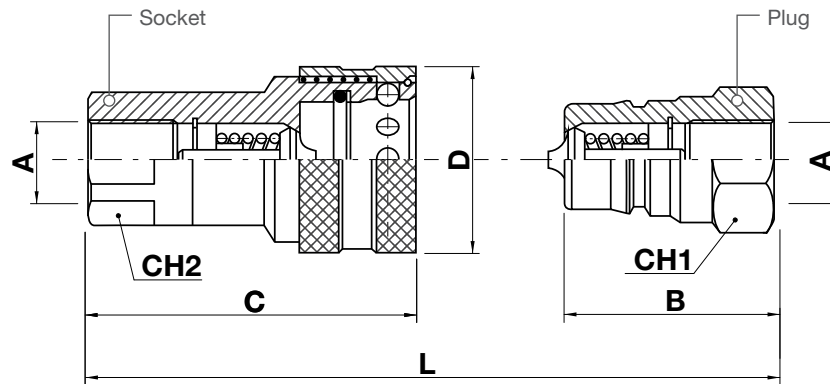

QUICK R. COUPLING

POPPET/BALL VALVE

FLAT FACE
SPECIAL APP.

SWIVEL JOINT

HYDRAULIC VALVE

size	Ø DN		code		Ø A	B		C		Ø D		L		CH1		CH2	
	mm	inch	plug	socket		mm	in	mm	in	mm	in	mm	in	mm	in	mm	in
02	5	1/8"	BM10-02	BF10-02	1/8" BSP	30	1,18	49	1,93	24	0,94	60,5	2,38	14	0,55	14	0,55
			BM15-02	BF15-02	1/8" NPTF												
04	6	1/4"	BM10-04	BF10-04	1/4" BSP	35	1,38	57	2,24	27	1,06	70,5	2,78	19	0,75	19	0,75
			BM15-04	BF15-04	1/4" NPTF												
06	10	3/8"	BM10-06	BF10-06	3/8" BSP	41	1,61	66	2,60	34	1,34	82,5	3,25	24	0,94	24	0,94
			BM15-06	BF15-06	3/8" NPTF												
08	12	1/2"	BM10-08	BF10-08	1/2" BSP	46	1,81	74	2,91	42	1,65	92,5	3,64	27	1,06	27	1,06
			BM15-08	BF15-08	1/2" NPTF												
12	20	3/4"	BM10-12	BF10-12	3/4" BSP	55	2,17	90	3,54	50	1,97	111	4,37	36	1,42	36	1,42
			BM15-12	BF15-12	3/4" NPTF												
16	25	1"	BM10-16	BF10-16	1" BSP	66	2,60	106	4,17	60	2,36	133	5,24	41	1,61	41	1,61
			BM15-16	BF15-16	1" NPTF												





MAIN DATA

- Standard material: steel;
- Plugs treated with induction hardening;
- Internal valves in hardened steel;
- Standard seals in nitril rubber;
- Back-up seals in teflon;
- Working temperature with standard nitril seals:
-20 °C / +110 °C.

On request

- Special seals: Viton, EPDM, Neoprene

PRESSURE DROP GRAPH

referred to poppet valve couplings

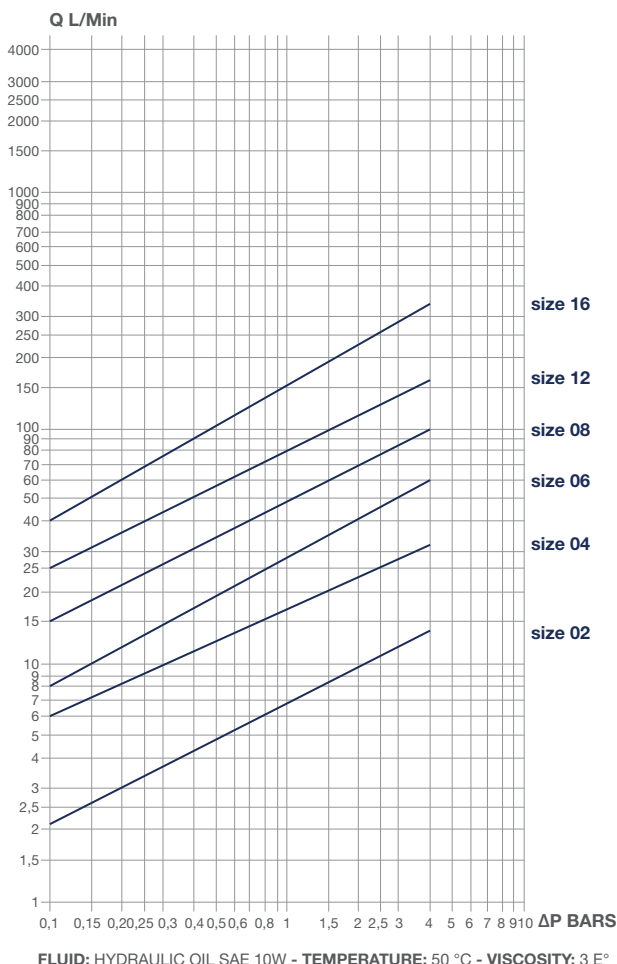

.....
QUICK R. COUPLING
POPPET/BALL VALVE

FLAT FACE
SPECIAL APP.

.....
SWIVEL JOINT

.....
HYDRAULIC VALVE

PERFORMANCES

size	Ø DN		maximum working pressure		burst pressure		weight			
							plug		socket	
	mm	inch	bar	psi	bar	psi	kg	lbs	kg	lbs
02	5	1/8"	350	5075	1400	20300	0,02	0,04	0,07	0,15
04	6	1/4"	350	5075	1400	20300	0,04	0,09	0,12	0,26
06	10	3/8"	300	4350	1200	17400	0,07	0,15	0,22	0,49
08	12	1/2"	280	4060	1120	16240	0,10	0,22	0,32	0,71
12	20	3/4"	180	2610	720	10440	0,20	0,44	0,59	1,30
16	25	1"	150	2175	600	8700	0,37	0,82	0,86	1,90



N



Ball locking coupling (size 1/2" is identical to A series, ISO 7241-A interchangeable)

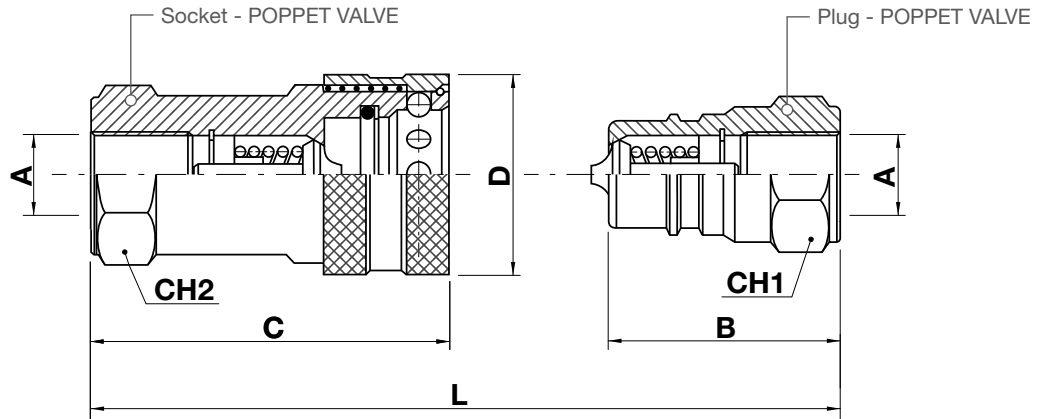

QUICK R. COUPLING
POPPET/BALL VALVE

FLAT FACE
 SPECIAL APP.

SWIVEL JOINT

HYDRAULIC VALVE

size	Ø DN		code		Ø A	B		C		Ø D		L		CH1		CH2	
	mm	inch	plug	socket		mm	in	mm	in	mm	in	mm	in	mm	in	mm	in
04	6	1/4"	NM10-04	NF10-04	1/4" BSP	35	1,38	52	2,05	27	1,06	70,5	2,78	19	0,75	21	0,83
			NM15-04	NF15-04	1/4" NPTF												
06	10	3/8"	NM10-06	NF10-06	3/8" BSP	39	1,54	60	2,36	35	1,38	80	3,15	22	0,87	27	1,06
			NM15-06	NF15-06	3/8" NPTF												
			NM18-06	NF18-06	3/8" BSPT												
08	12	1/2"	AM10-08	AF10-08	1/2" BSP	45	1,77	67	2,64	38	1,50	92	3,62	27	1,06	30	1,18
			AM15-08	AF15-08	1/2" NPTF												
			AM18-08	AF18-08	1/2" BSPT												
12	20	3/4"	NM10-12	NF10-12	3/4" BSP	53	2,09	82	3,23	46	1,81	106,5	4,19	34	1,34	38	1,50
			NM15-12	NF15-12	3/4" NPTF												
16	25	1"	NM10-16	NF10-16	1" BSP	58	2,28	95	3,74	55	2,17	120	4,72	41	1,61	45	1,77
			NM15-16	NF15-16	1" NPTF												



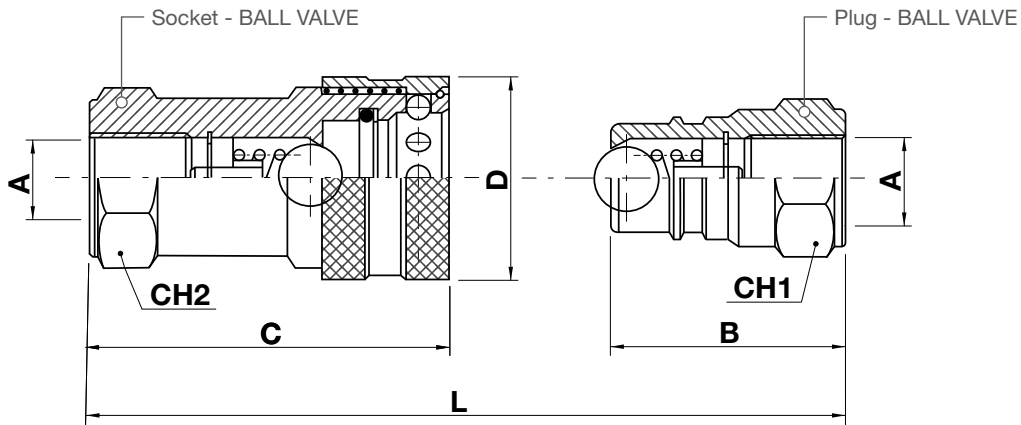

.....
QUICK R. COUPLING
POPPET/BALL VALVE

 FLAT FACE
 SPECIAL APP.

 SWIVEL JOINT

 HYDRAULIC VALVE

size	Ø DN		code		Ø A	B		C		Ø D		L		CH1		CH2	
	mm	inch	plug	socket		mm	in	mm	in	mm	in	mm	in	mm	in	mm	in
04	6	1/4"	NM20-04	NF20-04	1/4" BSP	35	1,38	52	2,05	27	1,06	70,5	2,78	19	0,75	21	0,83
			NM25-04	NF25-04	1/4" NPTF												
06	10	3/8"	NM20-06	NF20-06	3/8" BSP	39	1,54	60	2,36	35	1,38	80	3,15	22	0,87	27	1,06
			NM25-06	NF25-06	3/8" NPTF												
			NM28-06	NF28-06	3/8" BSPT												
08	12	1/2"	AM20-08	AF20-08	1/2" BSP	45	1,77	67	2,63	38	1,50	92	3,62	27	1,06	30	1,18
			AM25-08	AF25-08	1/2" NPTF												
			AM28-08	AF28-08	1/2" BSPT												
12	20	3/4"	NM20-12	NF20-12	3/4" BSP	53	2,09	82	3,23	46	1,81	106,5	4,19	34	1,34	38	1,50
			NM25-12	NF25-12	3/4" NPTF												
16	25	1"	NM20-16	NF20-16	1" BSP	68,5	2,70	103	4,05	56	2,17	120	4,72	41	1,61	45	1,77
			NM25-16	NF25-16	1" NPTF												





MAIN DATA

- Standard material: steel;
- Plugs treated with induction hardening;
- Internal valves in hardened steel;
- Standard seals in nitril rubber;
- Back-up seals in teflon;
- Working temperature with standard nitril seals: -20 °C / +110 °C.

On request

- Special seals: Viton, EPDM, Neoprene;
- Special 1/2" plug and socket for connection in presence of residual back pressure.

QUICK R. COUPLING

POPPET/BALL VALVE

FLAT FACE
SPECIAL APP.

SWIVEL JOINT

HYDRAULIC VALVE

PRESSURE DROP GRAPH

referred to poppet valve couplings

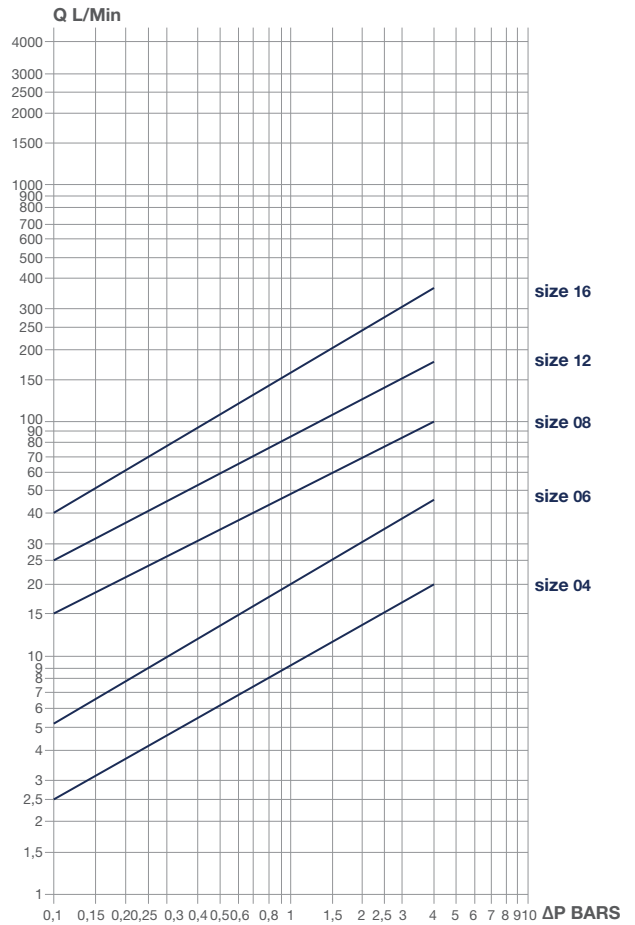

FLUID: HYDRAULIC OIL SAE 10W - TEMPERATURE: 50 °C - VISCOSITY: 3 E°

PERFORMANCES

size	Ø DN		maximum working pressure		burst pressure		weight			
							plug		socket	
	mm	inch	bar	psi	bar	psi	kg	lbs	kg	lbs
04	6	1/4"	350	5075	1400	20300	0,04	0,09	0,10	0,22
06	10	3/8"	315	4567,5	1260	18270	0,07	0,15	0,20	0,44
08	12	1/2"	250	3625	1000	14500	0,10	0,22	0,26	0,57
12	20	3/4"	250	3625	1000	14500	0,18	0,40	0,50	1,10
16	25	1"	230	3335	920	13340	0,29	0,64	0,76	1,68



P



Ball locking push pull coupling

ISO 7241-A / ISO 5675

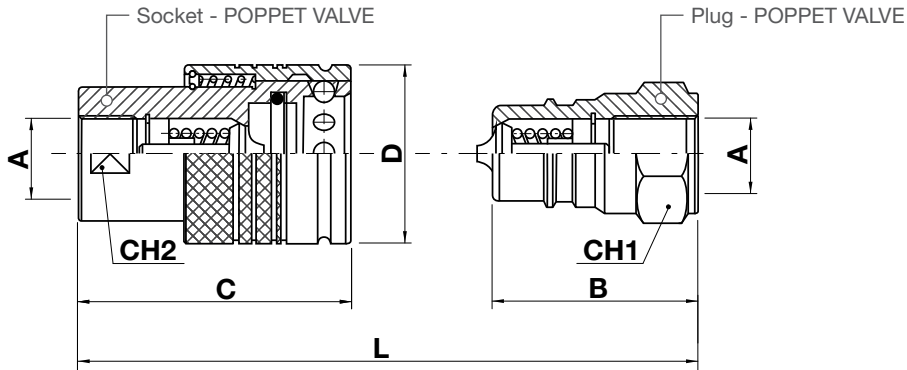

QUICK R. COUPLING
POPPET/BALL VALVE

FLAT FACE
SPECIAL APP.

SWIVEL JOINT

HYDRAULIC VALVE

size	Ø DN		code		Ø A	B		C		Ø D		L		CH1		CH2	
	mm	inch	plug	socket		mm	in	mm	in	mm	in	mm	in	mm	in	mm	in
08	12	1/2"	AM10-08	PF10-08	1/2" BSP	46	1,81	67	2,64	38	1,50	92	3,62	27	1,06	24	0,94
			AM15-08	PF15-08	1/2" NPT												

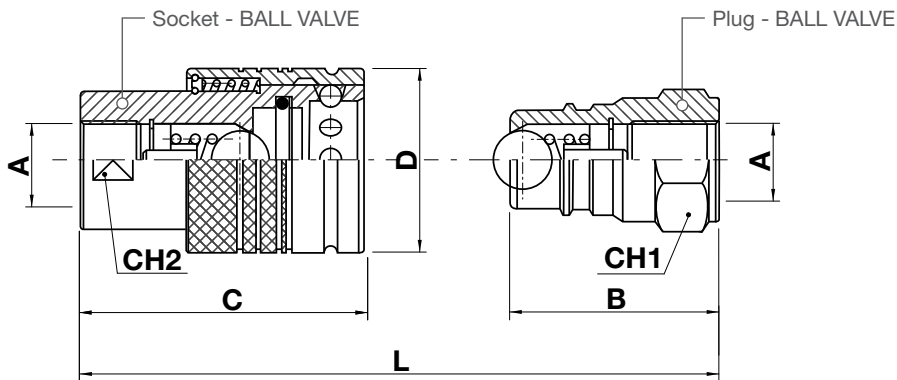

size	Ø DN		code		Ø A	B		C		Ø D		L		CH1		CH2	
	mm	inch	plug	socket		mm	in	mm	in	mm	in	mm	in	mm	in	mm	in
08	12	1/2"	AM20-08	PF20-08	1/2" BSP	46	1,81	67	2,64	38	1,50	92	3,62	27	1,06	24	0,94
			AM25-08	PF25-08	1/2" NPT												





Metric light / heavy

DIN 2353

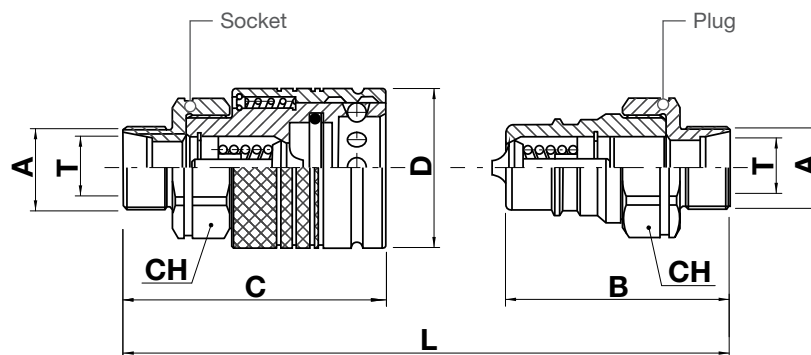

QUICK R. COUPLING

POPPET/BALL VALVE

FLAT FACE
SPECIAL APP.

SWIVEL JOINT

HYDRAULIC VALVE

METRIC LIGHT

size	Ø DN		code		Ø T	Ø A	B		C		Ø D		L		CH	
	mm	inch	plug	socket			mm	in	mm	in	mm	in	mm	in	mm	in
08	12	1/2"	AM11-08L	PF11-08L	8	M14X1,5	56	2,20	76	2,99	38	1,50	111	4,37	30	1,18
			AM11-10L	PF11-10L	10	M16X1,5	57	2,24	77	3,03	38	1,50	113	4,45	30	1,18
			AM11-12L	PF11-12L	12	M18X1,5	57	2,24	77	3,03	38	1,50	113	4,45	30	1,18
			AM11-15L	PF11-15L	15	M22X1,5	58	2,28	78	3,07	38	1,50	115	4,53	30	1,18
			AM11-18L	PF11-18L	18	M26X1,5	58	2,28	78	3,07	38	1,50	115	4,53	30	1,18

METRIC HEAVY

size	Ø DN		code		Ø T	Ø A	B		C		Ø D		L		CH1	
	mm	inch	plug	socket			mm	in	mm	in	mm	in	mm	in	mm	in
08	12	1/2"	AM12-08S	PF12-08S	8	M16X1,5	58	2,28	78	3,07	38	1,50	115	4,53	30	1,18
			AM12-10S	PF12-10S	10	M18X1,5	58	2,28	78	3,07	38	1,50	115	4,53	30	1,18
			AM12-12S	PF12-12S	12	M20X1,5	58	2,28	78	3,07	38	1,50	115	4,53	30	1,18
			AM12-14S	PF12-14S	14	M22X1,5	60	2,36	80	3,15	38	1,50	119	4,69	30	1,18
			AM12-16S	PF12-16S	16	M24X1,5	60	2,36	80	3,15	38	1,50	119	4,69	30	1,18
			AM12-20S	PF12-20S	20	M30X2	62	2,44	82	3,23	38	1,50	123	4,84	30	1,18





Bulk head - metric light / heavy

DIN 2353

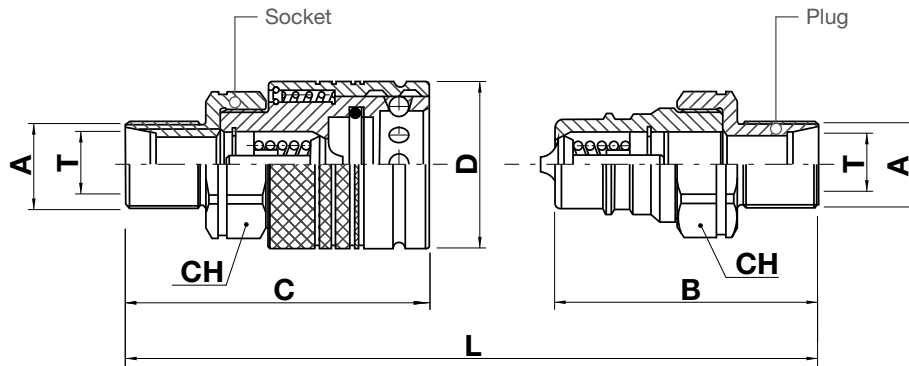

-
- QUICK R. COUPLING**
- POPPET/BALL VALVE**
-
- FLAT FACE
- SPECIAL APP.
-
- SWIVEL JOINT
-
- HYDRAULIC VALVE

METRIC LIGHT

size	Ø DN		code		Ø T	Ø A	B		C		Ø D		L		CH	
	mm	inch	plug	socket			mm	in	mm	in	mm	in	mm	in	mm	in
08	12	1/2"	AM13-08L	PF13-08L	8	M14X1,5	72	2,83	92	3,62	38	1,50	143	5,63	30	1,18
			AM13-10L	PF13-10L	10	M16X1,5	72	2,83	92	3,62	38	1,50	143	5,63	30	1,18
			AM13-12L	PF13-12L	12	M18X1,5	72	2,83	92	3,62	38	1,50	143	5,63	30	1,18
			AM13-15L	PF13-15L	15	M22X1,5	73	2,87	93	3,66	38	1,50	145	5,71	30	1,18
			AM13-18L	PF13-18L	18	M26X1,5	73	2,87	93	3,66	38	1,50	145	5,71	30	1,18

METRIC HEAVY

size	Ø DN		code		Ø T	Ø A	B		C		Ø D		L		CH	
	mm	inch	plug	socket			mm	in	mm	in	mm	in	mm	in	mm	in
08	12	1/2"	AM14-08S	PF14-08S	8	M16X1,5	73	2,87	93	3,66	38	1,50	145	5,71	30	1,18
			AM14-10S	PF14-10S	10	M18X1,5	73	2,87	93	3,66	38	1,50	145	5,71	30	1,18
			AM14-12S	PF14-12S	12	M20X1,5	73	2,87	93	3,66	38	1,50	145	5,71	30	1,18
			AM14-14S	PF14-14S	14	M22X1,5	75	2,95	95	3,74	38	1,50	149	5,87	30	1,18
			AM14-16S	PF14-18S	16	M24X1,5	75	2,95	95	3,74	38	1,50	149	5,87	30	1,18
			AM14-20S	PF14-20S	20	M30X2	78	3,07	98	3,86	38	1,50	155	6,10	30	1,18





MAIN DATA

- Poppet or ball valves;
- Material: steel;
- Poppet valve in hardened steel;
- Plug in hardened steel;
- Working temperatures with standard seals:
-20 °C / +110 °C;
- Standard seals in nitril rubber; Back-up ring in PTFE.

On request

- Special seals: special valve for connection in presence of residual back pressure

QUICK R. COUPLING
POPPET/BALL VALVE

FLAT FACE
SPECIAL APP.

SWIVEL JOINT

HYDRAULIC VALVE

PRESSURE DROP GRAPH

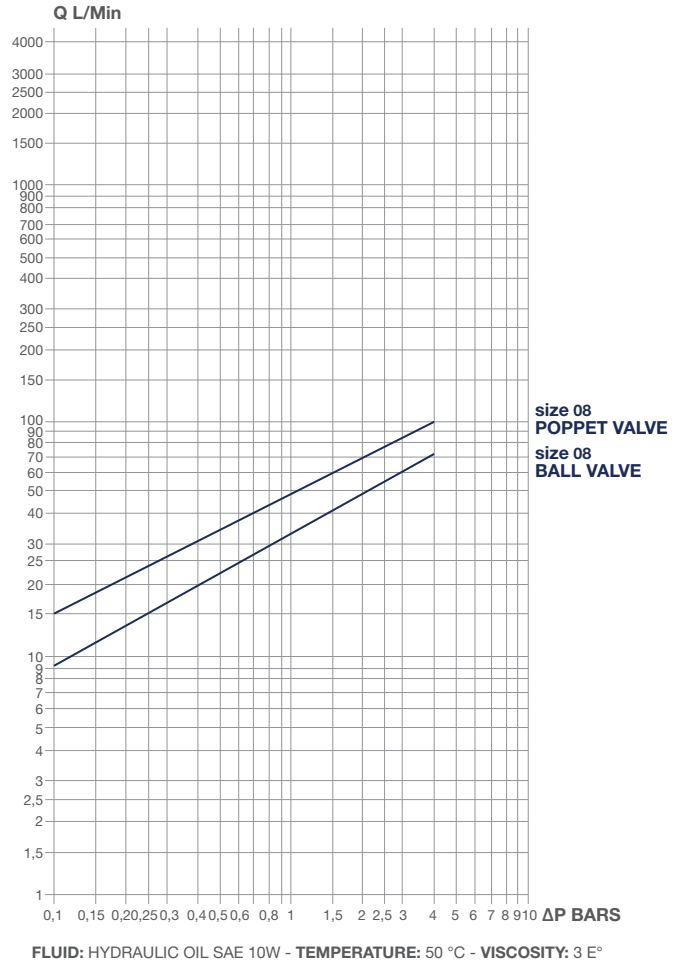

PERFORMANCES

size	Ø DN		maximum working pressure		burst pressure		weight			
	mm	inch	bar	psi	bar	psi	plug		socket	
							kg	lbs	kg	lbs
08	12	1/2"	250	3625	1000	14500	0,09	0,20	0,20	0,44



E



Ball locking large diameter coupling

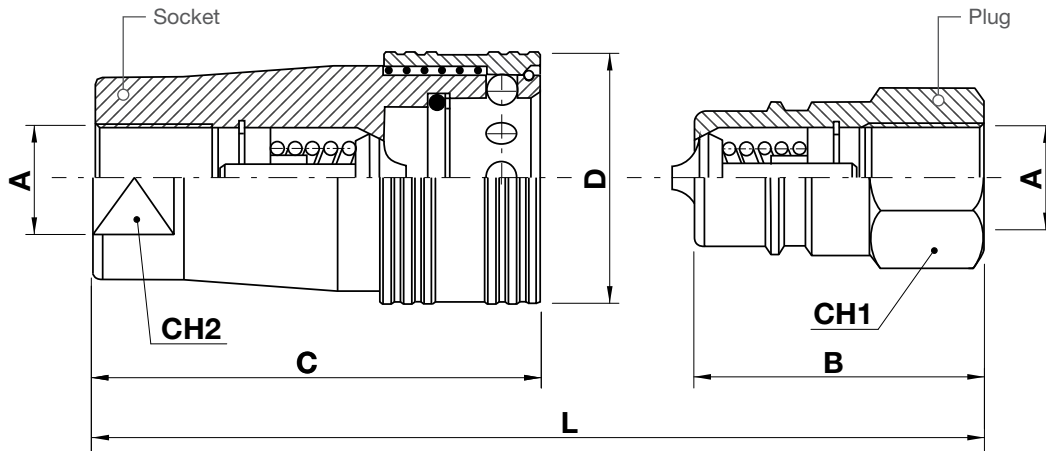

.....
QUICK R. COUPLING
POPPET/BALL VALVE

 FLAT FACE
 SPECIAL APP.

 SWIVEL JOINT

 HYDRAULIC VALVE

size	Ø DN		code		Ø A	B		C		Ø D		L		CH1		CH2	
	mm	inch	plug	socket		mm	in	mm	in	mm	in	mm	in	mm	in	mm	in
20	32	1.1/4"	EM10-20	EF10-20	1.1/4" BSP	70	2,76	110	4,33	70	2,75	140	5,51	50	1,97	50	1,97
			EM15-20	EF15-20	1.1/4" NPTF												
24	38	1.1/2"	EM10-24	EF10-24	1.1/2" BSP	70	2,76	114	4,49	81	3,18	141	5,55	60	2,36	55	2,17
			EM15-24	EF15-24	1.1/2" NPTF												
32	50	2"	EM10-32	EF10-32	2" BSP	89	3,50	139	5,47	114	4,49	177	6,97	70	2,76	70	2,76
			EM15-32	EF15-32	2" NPTF												
40	63	2.1/2"	EM10-40	EF10-40	2.1/2" BSP	89	3,50	139	5,47	114	4,49	177	6,97	84	3,30	84	3,30
			EM15-40	EF15-40	2.1/2" NPTF												
50	76	3"	EM10-50	EF10-50	3" BSP	100	3,94	155	6,10	139	5,47	200	7,87	100	3,94	100	3,94
			EM15-50	EF15-50	3" NPTF												





MAIN DATA

- Standard material: steel;
- Plugs treated with induction hardening;
- Internal valves in hardened steel;
- Standard seals in nitril rubber;
- Working temperature: -20 °C / +110 °C.

On request

- Special seals: Viton, EPDM, Neoprene;
- Free flow version;
- Brass version.

QUICK R. COUPLING
POPPET/BALL VALVE

FLAT FACE
SPECIAL APP.

SWIVEL JOINT

HYDRAULIC VALVE

PRESSURE DROP GRAPH

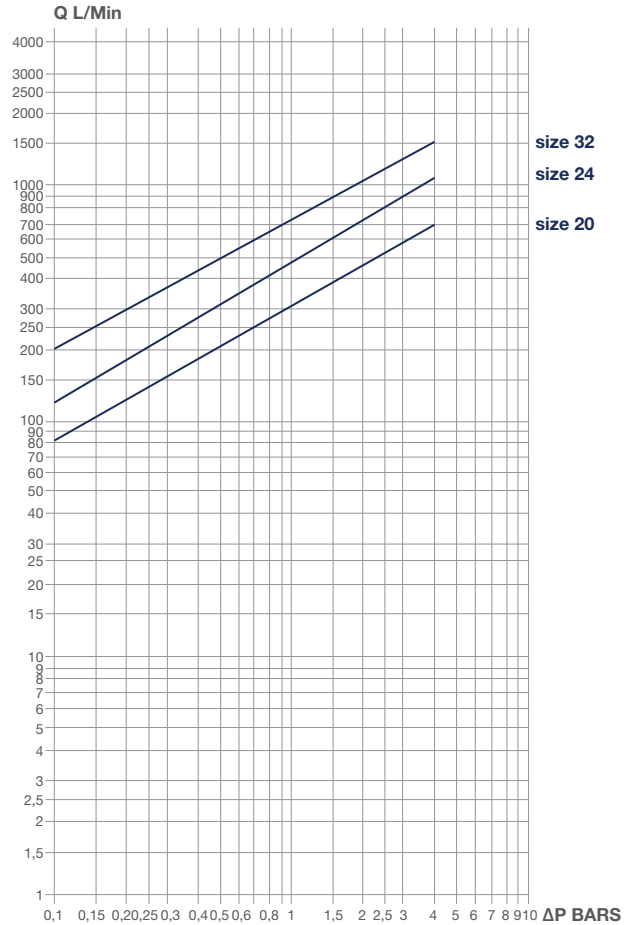

FLUID: HYDRAULIC OIL SAE 10W - TEMPERATURE: 50 °C - VISCOSITY: 3 E°

PERFORMANCES

size	Ø DN		maximum working pressure		burst pressure		weight			
							plug		socket	
	mm	inch	bar	psi	bar	psi	kg	lbs	kg	lbs
20	32	1.1/4"	140	2030	560	8120	0,46	1,01	1,38	3,04
24	38	1.1/2"	120	1740	480	6960	0,72	1,59	1,82	4,01
32	50	2"	120	1740	480	6960	2,02	4,45	4,42	9,74
40	63	2.1/2"	100	1450	400	5800	1,82	4,01	4,05	8,93
50	76	3"	70	1015	280	4060	3,23	7,12	7,00	15,43



S



Screw to connect coupling

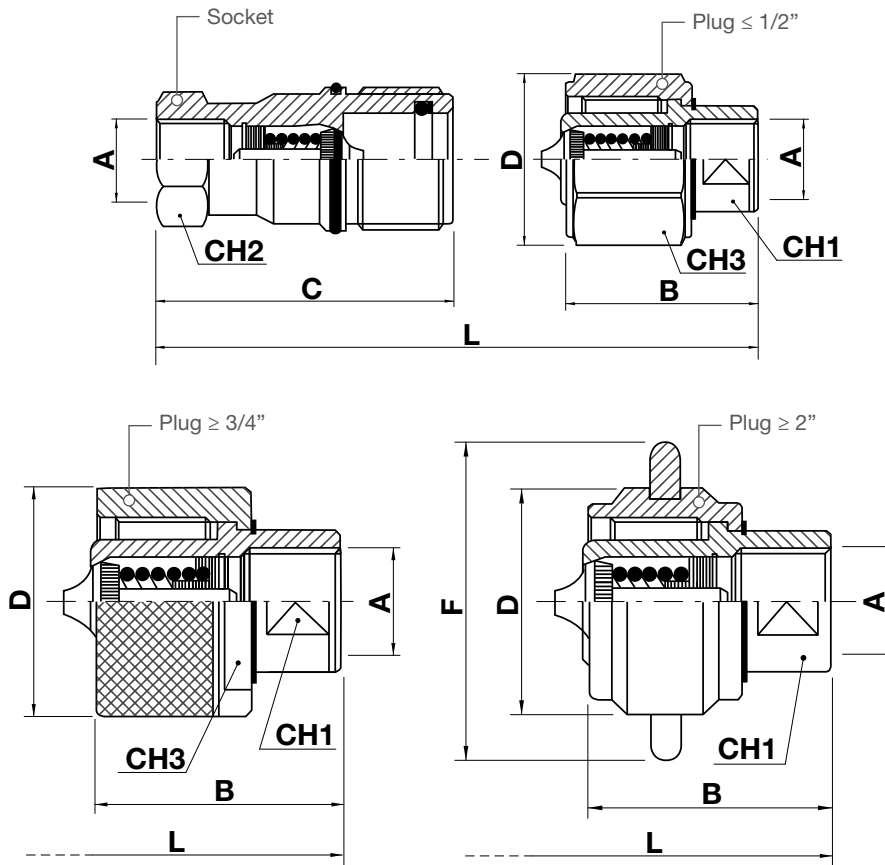

-
- QUICK R. COUPLING**
- POPPET/BALL VALVE**
-
- FLAT FACE
- SPECIAL APP.
-
- SWIVEL JOINT
-
- HYDRAULIC VALVE

size	Ø DN		code		Ø A	B		C		Ø D		L		CH1		CH2		CH3	
	mm	inch	plug	socket		mm	in	mm	in	mm	in	mm	in	mm	in	mm	in	mm	in
04	6	1/4"	SM10-04	SF10-04	1/4" BSP	46	1,81	50	1,97	31	1,22	72	2,83	17	0,70	19	0,75	28	1,10
06	10	3/8"	SM10-06	SF10-06	3/8" BSP	51	2,01	58	2,28	38	1,50	83	3,27	20	0,79	27	1,06	34	1,34
08	12	1/2"	SM10-08	SF10-08	1/2" BSP	54,5	2,14	75	2,95	47	1,85	100	3,94	27	1,06	32	1,26	42	1,65
12	20	3/4"	SM10-12	SF10-12	3/4" BSP	60	2,36	91	3,58	50	1,97	118	4,64	32	1,26	38	1,50	45	1,77
16	25	1"	SM10-16	SF10-16	1" BSP	70	2,75	89	3,50	60	2,36	120	4,72	41	1,61	45	1,77	55	2,16
20	32	1.1/4"	SM10-20	SF10-20	1.1/4" BSP	78	3,07	105	4,13	70	2,75	141	5,55	50	1,97	55	2,16	65	2,56
24	38	1.1/2"	SM10-24	SF10-24	1.1/2" BSP	80	3,15	105	4,13	90	3,54	141	5,55	55	2,16	60	2,36	75	2,95

size	Ø DN		code		Ø A	B		C		Ø D		L		CH1		CH2		F*	
	mm	inch	plug	socket		mm	in	mm	in	mm	in	mm	in	mm	in	mm	in	mm	in
32	50	2"	SM10-32	SF10-32	2" BSP	96	3,78	130	5,12	135	5,31	172	6,77	80	3,15	80	3,15	220	8,66

* N° 2 handles at 180°





MAIN DATA

- Standard material: carbon steel;
- Internal valves in hardened steel;
- Standard seals in nitril rubber;
- Back-up seals in teflon;
- Working temperature with standard seals: -20 °C / +110 °C;
- Applications: heavy duty hydraulic and industrial with high pressure, vibrations and mechanical stresses.

On request

- Special seals: Viton, EPDM, Neoprene

QUICK R. COUPLING
POPPET/BALL VALVE

FLAT FACE
SPECIAL APP.

SWIVEL JOINT

HYDRAULIC VALVE

PRESSURE DROP GRAPH

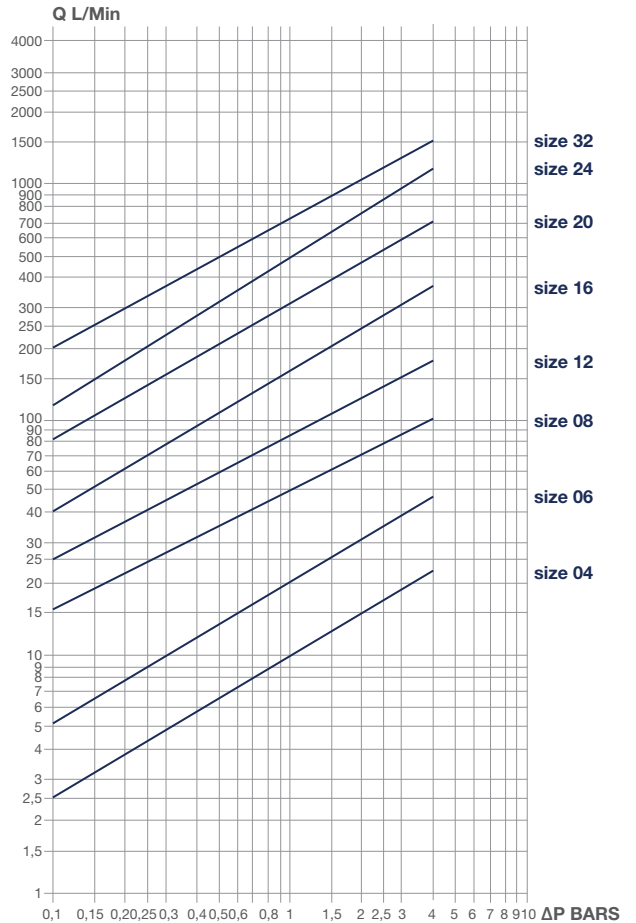

FLUID: HYDRAULIC OIL SAE 10W - TEMPERATURE: 50 °C - VISCOSITY: 3 E°

PERFORMANCES

size	Ø DN		maximum working pressure		burst pressure		weight			
							plug		socket	
	dn	inch	bar	psi	bar	psi	kg	lbs	kg	lbs
04	6	1/4"	450	6525	1800	26100	0,11	0,24	0,09	0,20
06	10	3/8"	450	6525	1800	26100	0,17	0,37	0,16	0,35
08	12	1/2"	400	5800	1600	23200	0,28	0,62	0,34	0,75
12	20	3/4"	350	5075	1400	20300	0,40	0,88	0,53	1,17
16	25	1"	350	5075	1400	20300	0,64	1,41	0,72	1,59
20	32	1.1/4"	250	3625	1000	14500	0,92	2,03	1,20	2,65
24	38	1.1/2"	220	3190	880	12700	1,24	2,73	1,35	2,98
32	50	2"	200	2900	800	11600	4,46	9,83	3,92	8,64





Screw to connect coupling

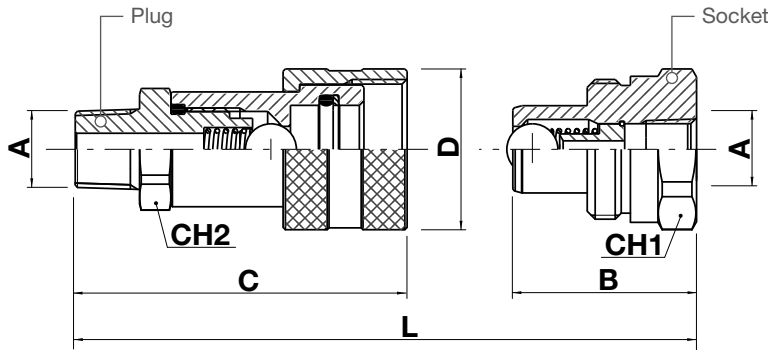

.....
QUICK R. COUPLING
POPPET/BALL VALVE
 FLAT FACE
 SPECIAL APP.

 SWIVEL JOINT

 HYDRAULIC VALVE

size	Ø DN		code		Ø A	B		C		Ø D		L		CH1		CH2	
	mm	inch	plug	socket		mm	in	mm	in	mm	in	mm	in	mm	in	mm	in
04	5	1/4"	JM25-04	JF25-04	1/4" NPT	32,5	1,28	60,8	2,39	28	1,10	74,5	2,93	19	0,75	22	0,87
06	7	3/8"	JM25-06	JF25-06	3/8" NPT	40	1,57	72,3	2,85	35	1,38	86,9	3,42	32	1,26	24	0,94

MAIN DATA

- Screw to connect;
- Material: steel;
- Ball valve;
- Silver colour zinc passivation;
- Standard seals in nitril rubber;
- Back-up seals in teflon;
- Working temperature with standard seals:
 -20 °C / +110 °C.

On request

- Metal caps

PERFORMANCES

size	Ø DN		maximum working pressure		burst pressure*		weight			
	dn	inch	bar	psi	bar	psi	plug		socket	
							kg	lbs	kg	lbs
04	5	1/4"	700	10150	2200	31900	0,08	0,18	0,15	0,33
06	7	3/8"	700	10150	1850	26825	0,12	0,26	0,20	0,44

* Coupled

F



Ball locking flat face coupling

ISO 16028 / NFPA T3.20.15 (HTMA) SIZE 3/8"

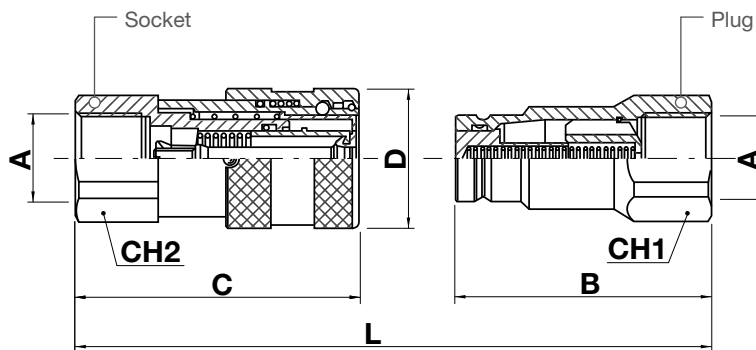

QUICK R. COUPLING

POPPET/BALL VALVE

FLAT FACE

SPECIAL APP.

SWIVEL JOINT

HYDRAULIC VALVE

size	Ø DN mm	code		Ø A	B		C		Ø D		L		CH1		CH2	
		plug	socket		mm	in	mm	in	mm	in	mm	in	mm	in		
04	7	FM10-04	FF10-04	1/4" BSP	48	1,89	48	1,89	28	1,10	85,5	3,37	22	0,87	22	0,87
		FM15-04	FF15-04	1/4" NPTF												
		FM18-04	FF18-04	1/4" BSPT												
06	9	FM10-06	FF10-06	3/8" BSP	60	2,36	64,5	2,54	32	1,26	109	4,29	24	0,94	27	1,06
		FM15-06	FF15-06	3/8" NPTF												
		FM18-06	FF18-06	3/8" BSPT												
06	9	FM10-08	FF10-08	1/2" BSP	62,5	2,46	69,5	2,74	32	1,26	117	4,59	27	1,06	27	1,06
		FM15-08	FF15-08	1/2" NPTF												
		FM18-08	FF18-08	1/2" BSPT												
08	13	FM20-08	FF20-08	1/2" BSP	68	2,68	73,5	2,89	38	1,50	125	4,92	32	1,26	32	1,26
		FM25-08	FF25-08	1/2" NPTF												
		FM28-08	FF28-08	1/2" BSPT												
08	13	FM10-12	FF10-12	3/4" BSP	70,5	2,78	80,5	3,17	38	1,50	135	5,30	36	1,42	36	1,42
		FM15-12	FF15-12	3/4" NPTF												
		FM18-12	FF18-12	3/4" BSPT												
12	15	FM20-12	FF20-12	3/4" BSP	70,5	2,78	78	3,07	42	1,65	132	5,20	36	1,42	36	1,42
		FM25-12	FF25-12	3/4" NPTF												
		FM28-12	FF28-12	3/4" BSPT												
16	17	FM10-16	FF10-16	1" BSP	82,5	3,25	92,5	3,64	48	1,89	154	6,06	45	1,77	45	1,77
		FM15-16	FF15-16	1" NPTF												
		FM18-16	FF18-16	1" BSPT												
20	21	FM10-20	FF10-20	1.1/4" BSP	90	3,54	105	4,13	55	2,17	173	6,81	55	2,17	55	2,17
		FM15-20	FF15-20	1.1/4" NPTF												
		FM18-20	FF18-20	1.1/4" BSPT												
24	30	FM10-24	FF10-24	1.1/2" BSP	111	4,37	133	5,22	80	3,15	215	8,46	70	2,76	65	2,56
		FM15-24	FF15-24	1.1/2" NPTF												
		FM18-24	FF18-24	1.1/2" BSPT												
32	45	FM10-32	FF10-32	2" BSP	125	4,92	165	6,50	100	3,94	250	9,84	75	2,95	80	3,15
		FM15-32	FF15-32	2" NPTF												
		FM18-32	FF18-32	2" BSPT												





MAIN DATA

- Sleeve with a safety device preventing from accidental disconnection;
- Standard seals in nitril rubber;
- Antiextrusion ring in teflon;
- Working temperature with standard seals: -20 °C +110 °C.

On request

- Special seals: Viton, EPDM

PRESSURE DROP GRAPH

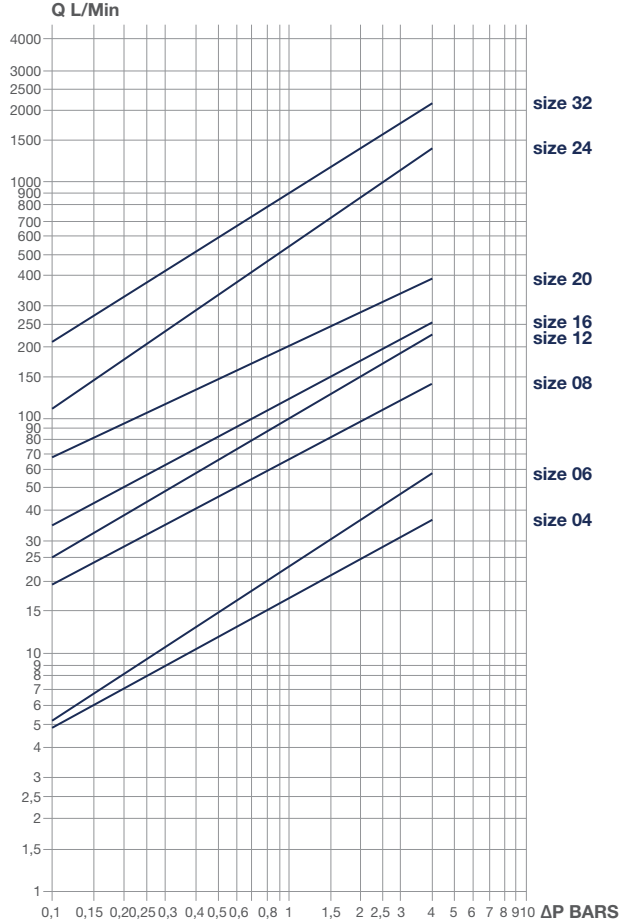

FLUID: HYDRAULIC OIL SAE 10W - TEMPERATURE: 50 °C - VISCOSITY: 3 E°

-
- QUICK R. COUPLING**
- POPPET/BALL VALVE
- FLAT FACE**
- SPECIAL APP.
-
- SWIVEL JOINT
-
- HYDRAULIC VALVE

PERFORMANCES

size	Ø DN	maximum working pressure		minimum burst pressure						weight				force to connect	
				coupled		plug		socket		plug		socket			
				bar	psi	bar	psi	bar	psi	bar	psi	kg	lbs		
04	7	300	4350	1200	17400	1200	17400	600	8700	0,05	0,11	0,08	0,18	18	39,68
06	9	300	4350	1200	17400	1200	17400	600	8700	0,06	0,13	0,15	0,33	17	37,48
06	9	300	4350	1200	17400	1200	17400	600	8700	0,09	0,20	0,27	0,60	17	37,48
08	13	250	3625	1000	14500	1000	14500	400	5800	0,09	0,20	0,27	0,60	18	39,68
08	13	250	3625	1000	14500	1000	14500	400	5800	0,19	0,42	0,47	1,04	18	39,68
12	15	250	3625	1000	14500	900	13050	450	6525	0,19	0,42	0,47	1,04	20	44,09
16	17	250	3625	850	12325	920	13340	550	7975	0,27	0,60	0,72	1,59	25	55,12
20	21	250	3625	850	12325	920	13340	470	6815	0,60	1,32	1,25	2,76	31	68,34
24	30	200	2900	700	10150	700	10150	300	4350	0,90	1,98	2,10	4,63	43	94,80
32	45	180	2610	700	10150	700	10150	500	7250	1,45	3,20	4,15	9,15	50	110,23



FA**Ball locking high pressure flat face coupling**

ISO 16028 / NFPA T3.20.15 (HTMA) SIZE 3/8"

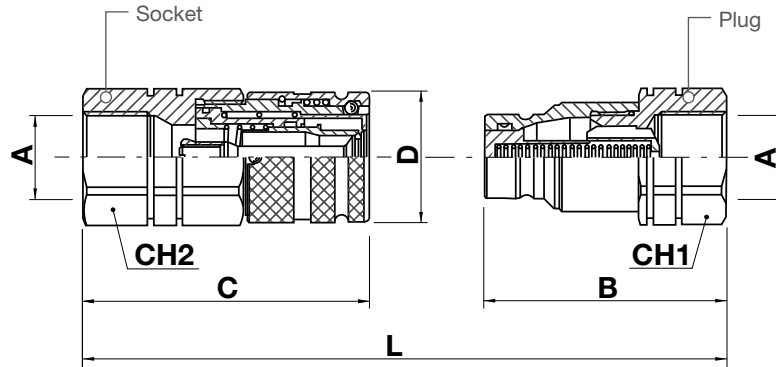
**QUICK R. COUPLING**

POPPET/BALL VALVE

FLAT FACE

SPECIAL APP.

SWIVEL JOINT

HYDRAULIC VALVE

size	Ø DN mm	code		Ø A	B		C		Ø D		L		CH1		CH2	
		plug	socket		mm	in	mm	in	mm	in	mm	in	mm	in	mm	in
02	4	FAM10-02	FAF10-02	1/8" BSP	36,5	1,44	40	1,57	20	0,79	68,5	2,70	17	0,67	19	0,75
		FAM15-02	FAF15-02	1/8" NPTF												
		FAM18-02	FAF18-02	1/8" BSPT												
04	7	FAM10-04	FAF10-04	1/4" BSP	48	1,89	53	2,09	28	1,10	90,5	3,56	22	0,87	27	1,06
		FAM15-04	FAF15-04	1/4" NPTF												
		FAM18-04	FAF18-04	1/4" BSPT												
06	9	FAM10-06	FAF10-06	3/8" BSP	60	2,36	64,5	2,54	32	1,26	109	4,29	27	1,06	30	1,18
		FAM15-06	FAF15-06	3/8" NPTF												
		FAM18-06	FAF18-06	3/8" BSPT												
06	9	FAM10-08	FAF10-08	1/2" BSP	62,5	2,46	69,5	2,74	32	1,26	116,5	4,59	27	1,06	30	1,18
		FAM15-08	FAF15-08	1/2" NPTF												
		FAM18-08	FAF18-08	1/2" BSPT												
08	13	FAM20-08	FAF20-08	1/2" BSP	68	2,68	76,5	3,01	38	1,50	127,5	5,02	36	1,42	36	1,42
		FAM25-08	FAF25-08	1/2" NPTF												
		FAM28-08	FAF28-08	1/2" BSPT												
08	13	FAM10-12	FAF10-12	3/4" BSP	70,5	2,78	83,5	3,29	38	1,50	137	4,39	36	1,42	36	1,42
		FAM15-12	FAF15-12	3/4" NPTF												
		FAM18-12	FAF18-12	3/4" BSPT												
12	15	FAM20-12	FAF20-12	3/4" BSP	73	2,87	83,5	3,29	42	1,65	139,5	5,49	36	1,42	41	1,61
		FAM25-12	FAF25-12	3/4" NPTF												
		FAM28-12	FAF28-12	3/4" BSPT												
16	17	FAM10-16	FAF10-16	1" BSP	84	3,31	98,5	3,88	48	1,89	161	6,34	46	1,81	46	1,81
		FAM15-16	FAF15-16	1" NPTF												
		FAM18-16	FAF18-16	1" BSPT												
20	21	FAM10-20	FAF10-20	1.1/4" BSP	90	3,54	105	4,13	55	2,17	173	6,81	55	2,17	55	2,17
		FAM15-20	FAF15-20	1.1/4" NPTF												
		FAM18-20	FAF18-20	1.1/4" BSPT												
24	30	FAM10-24	FAF10-24	1.1/2" BSP	111	4,37	132,5	5,22	80	3,15	215	8,46	65	2,56	65	2,56
		FAM15-24	FAF15-24	1.1/2" NPTF												
		FAM18-24	FAF18-24	1.1/2" BSPT												



← FA

MAIN DATA

- All sizes dimensionally interchangeable with our F series;
- Sleeve with a safety device preventing from accidental disconnection;
- Standard seals in nitril rubber;
- Antiextrusion ring in teflon;
- Working temperature with standard seals: -20 °C / +110 °C;
- Body size 3/8 (DN 9) is interchangeable according to HTMA design.

On request

- Special seals: Viton, EPDM;
- FPM plug special version for connection by hand with back pressure up to 200 bar, available in sizes 1/4" to 1".

PRESSURE DROP GRAPH

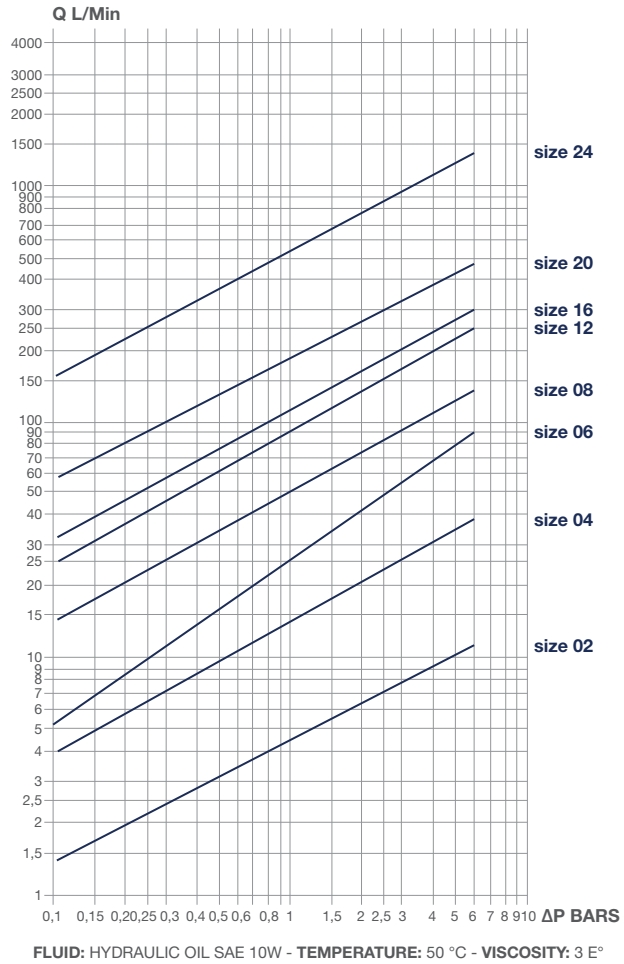

.....
QUICK R. COUPLING
 POPPET/BALL VALVE
FLAT FACE
 SPECIAL APP.

 SWIVEL JOINT

 HYDRAULIC VALVE

PERFORMANCES

size	Ø DN mm	maximum working pressure		minimum burst pressure						weight				force to connect	
				coupled		plug		socket		plug		socket			
				bar	psi	bar	psi	bar	psi	bar	psi	kg	lbs		
02	4	400	5800	1400	20300	1600	23200	1400	20300	0,03	0,07	0,09	0,20	15	33,07
04	7	400	5800	1200	17400	1200	17400	1100	15950	0,06	0,13	0,19	0,42	17	37,48
06	9	375	5438	1100	15950	1100	15950	1100	15950	0,15	0,33	0,26	0,57	21	46,30
06	9	375	5438	1100	15950	1100	15950	1100	15950	0,15	0,33	0,27	0,60	21	46,30
08	13	350	5075	1100	15950	1100	15950	1000	14500	0,27	0,60	0,45	0,99	23	50,71
08	13	350	5075	1100	15950	1100	15950	1000	14500	0,27	0,60	0,45	0,99	23	50,71
12	15	350	5075	1100	15950	1100	15950	900	13050	0,30	0,66	0,62	1,37	18	39,68
16	17	350	5075	1100	15950	1100	15950	900	13050	0,41	0,90	0,94	2,07	22	48,50
20	21	350	5075	1100	15950	1100	15950	800	11600	0,61	1,34	1,36	3,00	35	77,16
24	30	250	3625	1000	14500	1000	14500	800	11600	1,63	3,59	3,32	7,32	44	97,00

←



Ball locking coupling

ISO 7241-B

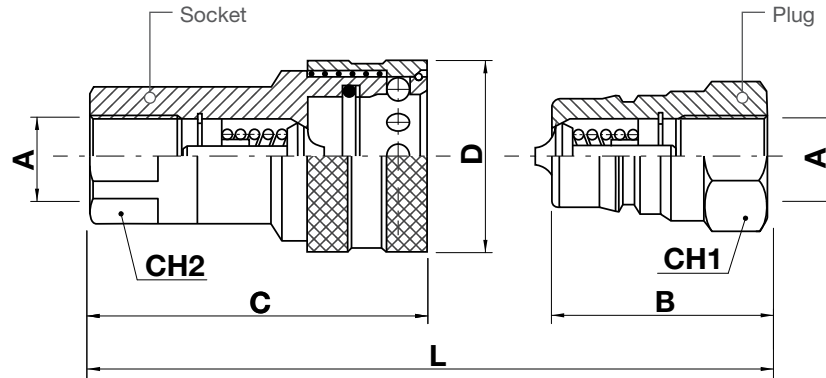

QUICK R. COUPLING

POPPET/BALL VALVE

FLAT FACE

SPECIAL APP.

SWIVEL JOINT

HYDRAULIC VALVE

size	Ø DN		code		Ø A	B		C		Ø D		L		CH1		CH2	
	mm	inch	plug	socket		mm	in	mm	in	mm	in	mm	in	mm	in	mm	in
02	5	1/8"	XM10-02	XF10-02	1/8" BSP	30	1,18	49	1,93	24	0,94	60,5	2,38	14	0,55	14	0,55
			XM15-02	XF15-02	1/8" NPTF												
04	6,3	1/4"	XM10-04	XF10-04	1/4" BSP	35	1,38	57	2,24	27	1,06	70,5	2,78	19	0,75	19	0,75
			XM15-04	XF15-04	1/4" NPTF												
06	10	3/8"	XM10-06	XF10-06	3/8" BSP	41	1,61	66	2,60	34	1,34	82,5	3,25	24	0,94	24	0,94
			XM15-06	XF15-06	3/8" NPTF												
08	12,5	1/2"	XM10-08	XF10-08	1/2" BSP	46	1,81	74	2,91	42	1,65	92,5	3,64	27	1,06	27	1,06
			XM15-08	XF15-08	1/2" NPTF												
12	20	3/4"	XM10-12	XF10-12	3/4" BSP	55	2,17	90	3,54	50	1,97	111	4,37	36	1,42	36	1,42
			XM15-12	XF15-12	3/4" NPTF												
16	25	1"	XM10-16	XF10-16	1" BSP	66	2,60	106	4,17	60	2,36	133	5,24	41	1,61	41	1,61
			XM15-16	XF15-16	1" NPTF												





MAIN DATA

- Material: AISI 316 stainless steel;
- Internal valves and components in AISI 316;
- Standard seals in Viton;
- Working temperature range with standard Viton seals: -15 °C / +180 °C;
- Applications: water or corrosive media and in corrosive environments.

On request

- Special seals

PRESSURE DROP GRAPH

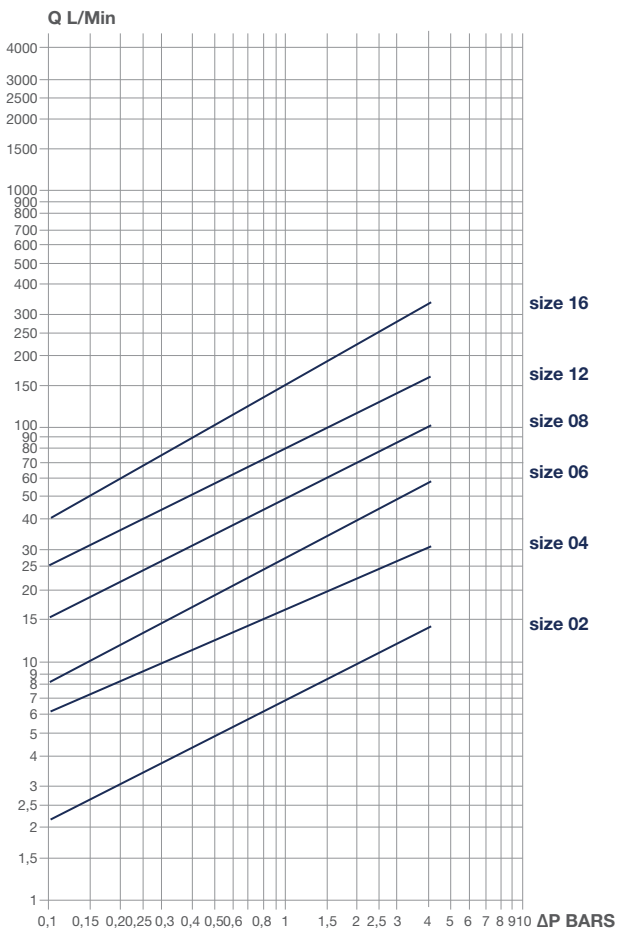

FLUID: HYDRAULIC OIL SAE 10W - TEMPERATURE: 50 °C - VISCOSITY: 3 E°

.....
QUICK R. COUPLING

POPPET/BALL VALVE

FLAT FACE

SPECIAL APP.

.....
SWIVEL JOINT

.....
HYDRAULIC VALVE

PERFORMANCES

size	Ø DN		maximum working pressure		burst pressure		weight			
							plug		socket	
	mm	inch	bar	psi	bar	psi	kg	lbs	kg	lbs
02	5	1/8"	150	2175	600	8700	0,02	0,04	0,07	0,15
04	6,3	1/4"	150	2175	600	8700	0,04	0,09	0,12	0,26
06	10	3/8"	100	1450	400	5800	0,07	0,15	0,22	0,49
08	12,5	1/2"	100	1450	400	5800	0,10	0,22	0,32	0,71
12	20	3/4"	100	1450	400	5800	0,20	0,44	0,59	1,30
16	25	1"	75	1087	300	4350	0,37	0,82	0,86	1,90



R



Ball locking coupling

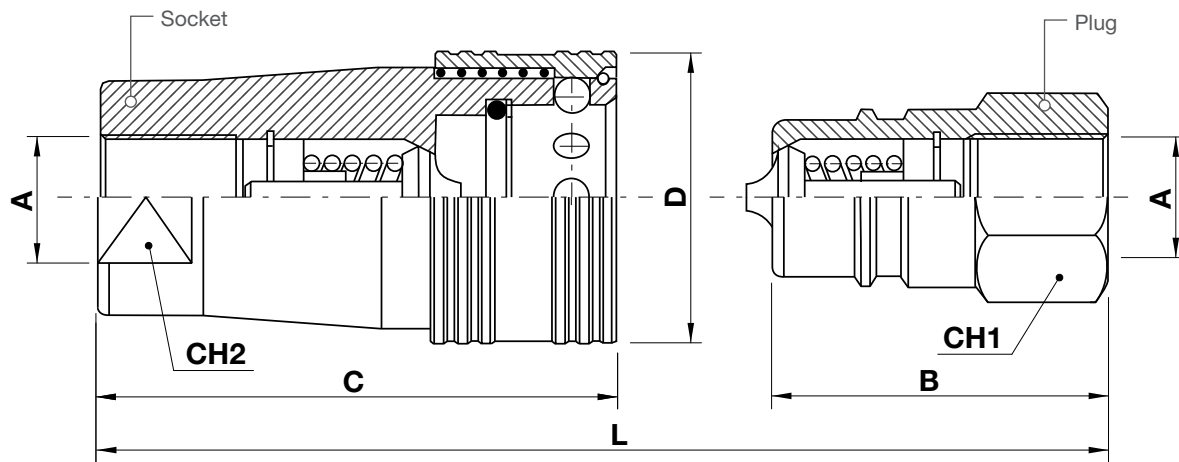

QUICK R. COUPLING

POPPE/T/BALL VALVE

FLAT FACE

SPECIAL APP.

SWIVEL JOINT

HYDRAULIC VALVE

size	Ø DN		code		Ø A	B		C		Ø D		L		CH1		CH2	
	mm	inch	plug	socket		mm	in	mm	in	mm	in	mm	in	mm	in	mm	in
20	32	1.1/4"	RM10-20	RF10-20	1.1/4" BSP	70	2,76	110	4,33	70	2,75	140	5,51	50	1,97	50	1,97
			RM15-20	RF15-20	1.1/4" NPTF												
			RM18-20	RF18-20	1.1/4" BSPT												
24	38	1.1/2"	RM10-24	RF10-24	1.1/2" BSP	70	2,76	114	4,49	81	3,18	140	5,51	60	2,36	55	2,17
			RM15-24	RF15-24	1.1/2" NPTF												
			RM18-24	RF18-24	1.1/2" BSPT												
32	50	2"	RM10-32	RF10-32	2" BSP	89	3,50	139	5,47	113	4,45	177	6,97	70	2,76	70	2,76
			RM15-32	RF15-32	2" NPTF												
			RM18-32	RF18-32	2" BSPT												
40	63	2.1/2"	RM10-40	RF10-40	2.1/2" BSP	89	3,50	139	5,47	113	4,45	177	6,97	84	3,30	84	3,30
			RM15-40	RF15-40	2.1/2" NPTF												
			RM18-40	RF18-40	2.1/2" BSPT												





MAIN DATA

- Material: AISI 316 stainless steel;
- Internal valves and components in AISI 316;
- Standard seals in NBR;
- Working temperature range with standard Viton seals: -15 °C / +180 °C;
- Applications: water or corrosive media.

On request

- Special seals;
- Free flow version.

PRESSURE DROP GRAPH

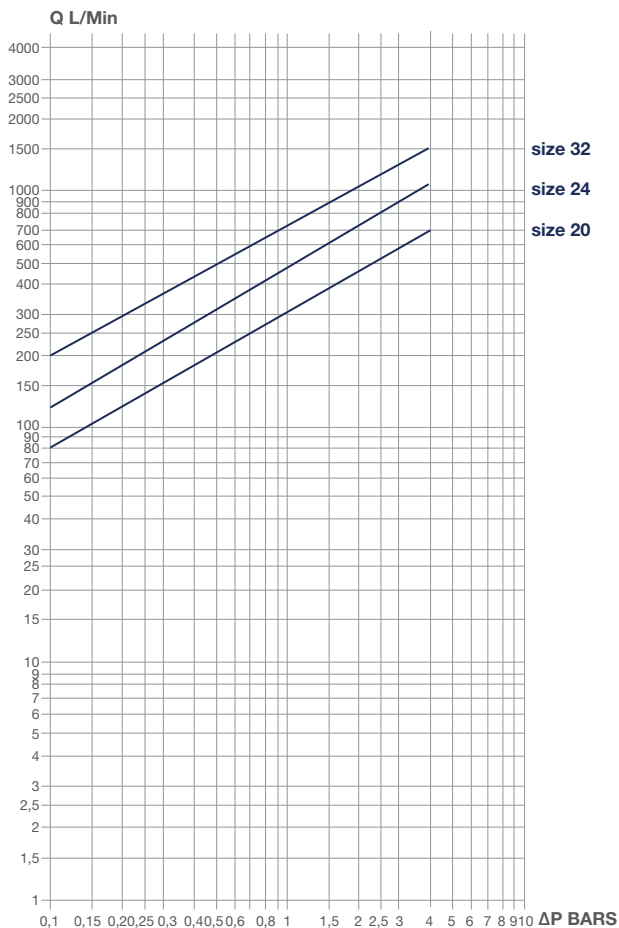

FLUID: HYDRAULIC OIL SAE 10W - TEMPERATURE: 50 °C - VISCOSITY: 3 E°

-
- QUICK R. COUPLING**
- POPPET/BALL VALVE
- FLAT FACE
- SPECIAL APP.**
-
- SWIVEL JOINT
-
- HYDRAULIC VALVE

PERFORMANCES

size	Ø DN		maximum working pressure		burst pressure		weight			
	mm	inch	bar	psi	bar	psi	plug		socket	
							kg	lbs	kg	lbs
20	32	1.1/4"	50	725	200	2900	0,46	1,01	1,38	3,04
24	38	1.1/2"	40	580	160	2320	0,72	1,59	1,82	4,01
32	50	2"	30	435	120	1740	2,02	4,45	4,42	9,74
40	63	2.1/2"	20	290	80	1160	1,82	4,01	4,05	8,93



Z



Screw to connect coupling

QUICK R. COUPLING

POPET/BALL VALVE

FLAT FACE

SPECIAL APP.

SWIVEL JOINT

HYDRAULIC VALVE

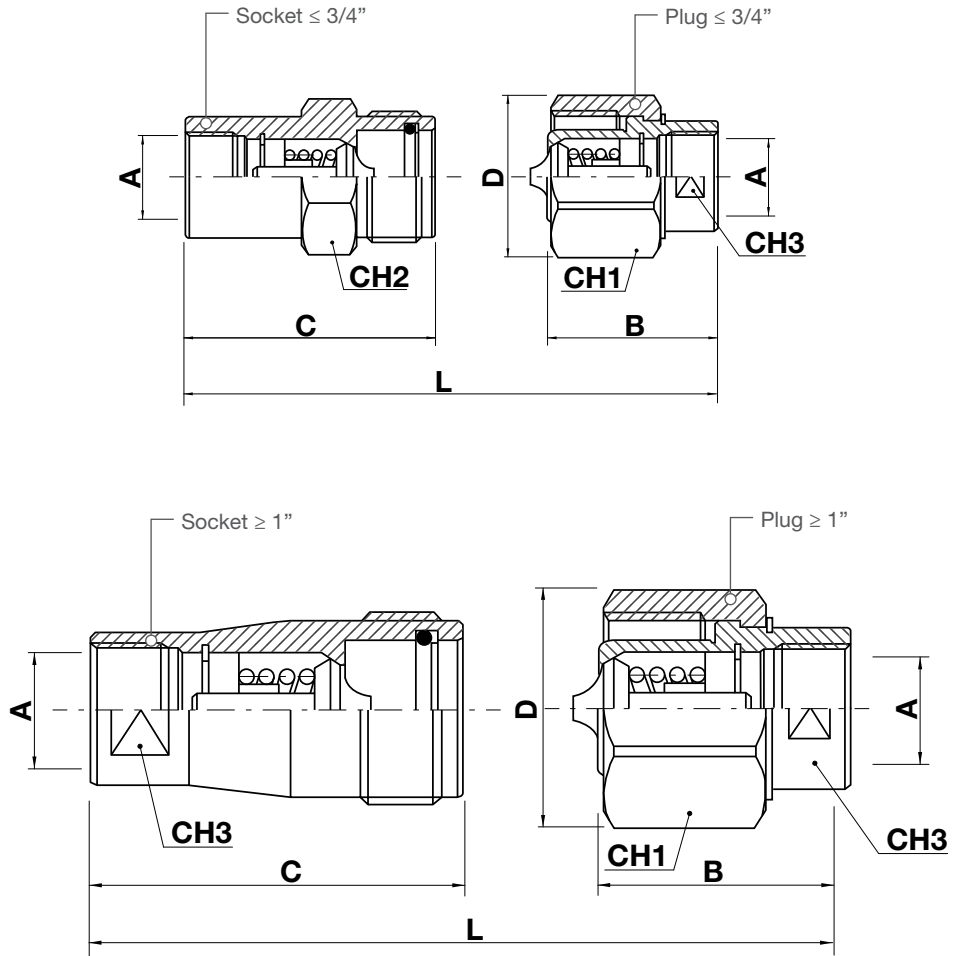

size	Ø DN		code		Ø A	B		C		Ø D		L		CH1		CH2		CH3	
	mm	inch	plug	socket		mm	in	mm	in	mm	in	mm	in	mm	in	mm	in	mm	in
			ZM10-04	ZF10-04	1/4" BSP														
04	6	1/4"	ZM15-04	ZF15-04	1/4" NPTF	36	1,42	50	1,97	31	1,22	69	2,72	28	1,10	24	0,94	16	0,63
			ZM18-04	ZF18-04	1/4" BSPT														
			ZM10-06	ZF10-06	3/8" BSP														
06	10	3/8"	ZM15-06	ZF15-06	3/8" NPTF	42	1,65	57	2,24	38	1,50	82	3,23	34	1,34	30	1,18	20	0,79
			ZM18-06	ZF18-06	3/8" BSPT														





size	Ø DN		code		Ø A	B		C		Ø D		L		CH1		CH2		CH3		
	mm	inch	plug	socket		mm	in	mm	in	mm	in	mm	in	mm	in	mm	in	mm	in	
08	12	1/2"	ZM10-08	ZF10-08	1/2" BSP															
			ZM15-08	ZF15-08	1/2" NPTF	55	2,17	75	2,95	47	1,85	100	3,94	42	1,65	38	1,50	27	1,06	
			ZM18-08	ZF18-08	1/2" BSPT															
12	20	3/4"	ZM10-12	ZF10-12	3/4" BSP															
			ZM15-12	ZF15-12	3/4" NPTF	61	2,40	90	3,54	56	2,20	114	4,49	50	1,97	42	1,65	30	1,18	
			ZM18-12	ZF18-12	3/4" BSPT															
16	25	1"	ZM10-16	ZF10-16	1" BSP															
			ZM15-16	ZF15-16	1" NPTF	61	2,40	88	3,46	67	2,64	120	4,72	60	2,36	-	-	40	1,57	
			ZM18-16	ZF18-16	1" BSPT															
20	32	1.1/4"	ZM10-20	ZF10-20	1.1/4" BSP															
			ZM15-20	ZF15-20	1.1/4" NPTF	70	2,76	105	4,13	79	3,11	140	5,51	70	2,76	-	-	48	1,89	
			ZM18-20	ZF18-20	1.1/4" BSPT															
24	38	1.1/2"	ZM10-24	ZF10-24	1.1/2" BSP															
			ZM15-24	ZF15-24	1.1/2" NPTF	70	2,76	105	4,13	90	3,54	140	5,51	80	3,15	-	-	52	2,05	
			ZM18-24	ZF18-24	1.1/2" BSPT															
32	50	2"	ZM10-32	ZF10-32	2" BSP															
			ZM15-32	ZF15-32	2" NPTF	86	3,39	130	5,12	128	5,04	173	6,81	120	4,72	-	-	80	3,15	
			ZM18-32	ZF18-32	2" BSPT															
40	63	2.1/2"	ZM10-40	ZF10-40	2.1/2" BSP															
			ZM15-40	ZF15-40	2.1/2" NPTF	86	3,39	130	5,12	128	5,04	173	6,81	120	4,72	-	-	85	3,35	
			ZM18-40	ZF18-40	2.1/2" BSPT															

.....
QUICK R. COUPLING

POPPET/BALL VALVE

FLAT FACE

SPECIAL APP.

.....
SWIVEL JOINT

.....
HYDRAULIC VALVE





MAIN DATA

- Material: AISI 316 stainless steel;
- Internal valves and components in AISI 316;
- Locking sleeve in AISI 316 treated with QPQ;
- Standard seals in nitril rubber;
- Working temperature: -20 °C +110 °C;
- Applications: either corrosive media or in corrosive environmental conditions.

On request

- Special seals: Viton, EPDM, Neoprene

QUICK R. COUPLING

POPPET/BALL VALVE

FLAT FACE

SPECIAL APP.

SWIVEL JOINT

HYDRAULIC VALVE

PRESSURE DROP GRAPH

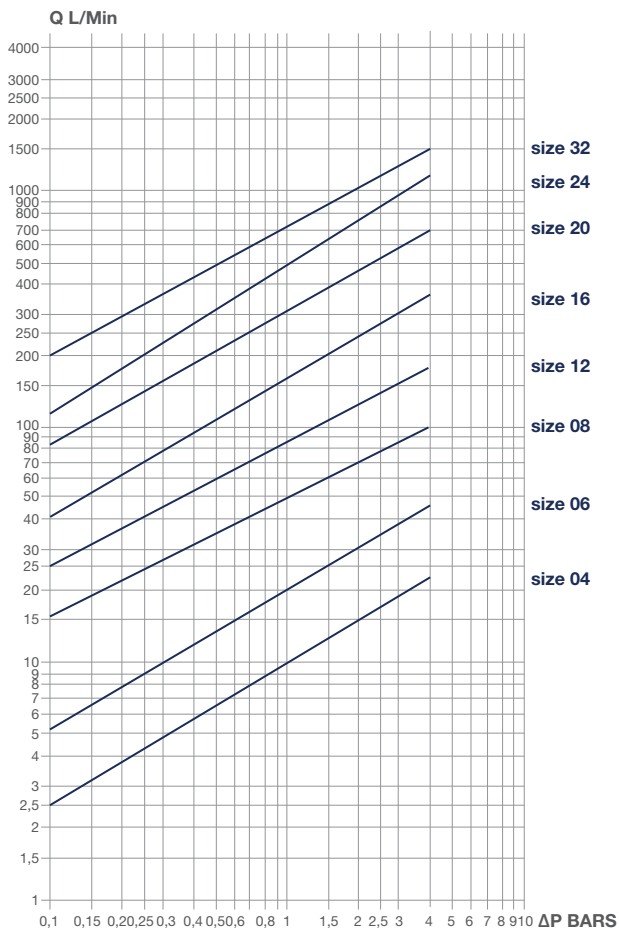

FLUID: HYDRAULIC OIL SAE 10W - TEMPERATURE: 50 °C - VISCOSITY: 3 E°

PERFORMANCES

size	Ø DN		maximum working pressure		burst pressure		weight			
	mm	inch	bar	psi	bar	psi	plug		socket	
							kg	lbs	kg	lbs
04	6	1/4"	500	7250	2000	29000	0,08	0,18	0,10	0,22
06	10	3/8"	450	6525	1800	26100	0,15	0,33	0,18	0,40
08	12	1/2"	400	5800	1600	23200	0,26	0,57	0,39	0,86
12	20	3/4"	350	5075	1400	20300	0,37	0,82	0,55	1,21
16	25	1"	300	4350	1200	17400	0,66	1,46	0,70	1,54
20	32	1.1/4"	250	3525	1000	14500	1,00	2,20	1,03	2,27
24	38	1.1/2"	220	3190	880	12760	1,35	2,98	1,20	2,64
32	50	2"	150	2175	600	8700	4,10	9,04	3,63	8,00
40	63	2.1/2"	120	1740	480	6960	3,64	8,02	3,30	7,28



Straight swivel joint

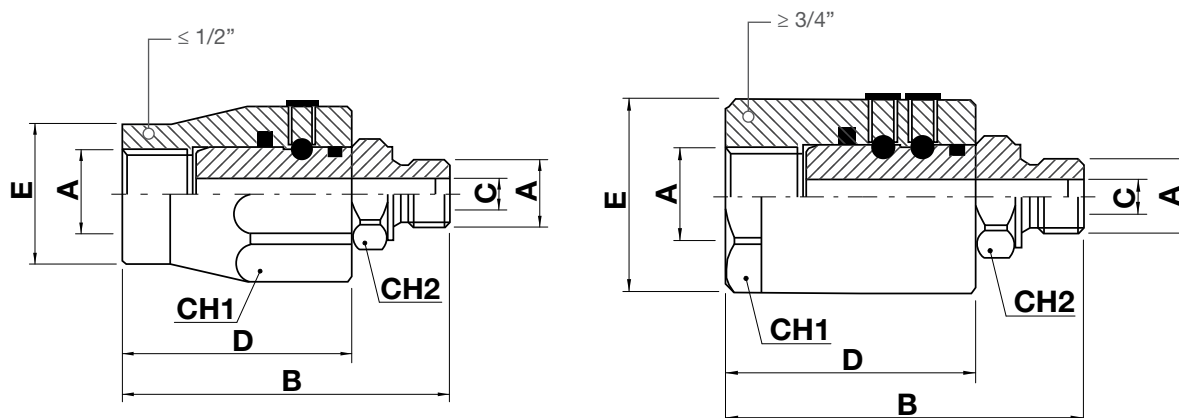

QUICK R. COUPLING

SWIVEL JOINT

HYDRAULIC VALVE

code	Ø A		B		C		D		Ø E		CH1		CH2		max. pressure in rotation		static max. pressure	
	inch	mm	in	mm	in	mm	in	mm	in	mm	in	mm	in	bar	psi	bar	psi	
SJ10-04	1/4"	61	2,40	6	0,24	42	1,65	24	0,94	30	1,18	19	0,75	200	2900	400	5800	
SJ10-06	3/8"	66	2,60	8,5	0,33	44	1,73	25	0,98	34	1,34	24	0,94	200	2900	400	5800	
SJ10-08	1/2"	71	2,80	11,5	0,45	47	1,85	32	1,26	36	1,42	27	1,06	150	2175	300	4350	
SJ10-12	3/4"	89	3,50	15	0,59	60	2,36	49,5	1,95	45	1,77	34	1,34	150	2175	300	4350	
SJ10-16	1"	98	3,86	20	0,79	65	2,56	54,5	2,15	50	1,97	41	1,61	100	1450	300	4350	
SJ10-20	1.1/4"	101	3,98	28	1,10	63	2,48	60	2,36	55	2,17	50	1,97	100	1450	300	4350	
SJ10-24	1.1/2"	110	4,33	35	1,38	70	2,76	69,5	2,74	65	2,56	55	2,17	80	1160	300	4350	
SJ10-32	2"	119	4,69	44	1,73	75	2,95	84,5	3,33	75	2,95	65	2,56	50	725	250	3625	

MAIN DATA

- Only for occasional rotations;
- Not suitable for continuous or fast rotation;
- Standard seals in nitril rubber;
- Working temperatures with standard seals:
-20 °C / +110 °C;
- Standard thread: BSP (GAS);
- Applications: mounted between a hose and a rigid component compensates for occasional rotation, preventing damage to the hose.

On request

- Special materials: AISI 303, AISI 316, Brass;
- Special seals: Viton, EPDM, Silicone;
- Special thread: NPTF, Metric, UNF.

SJ90

90° swivel joint

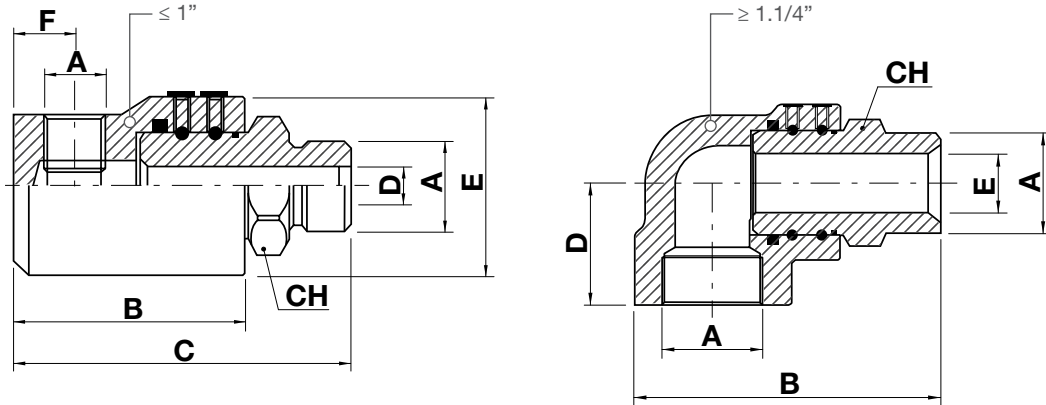

code	Ø A		B		C		D		Ø E		F		CH		max. pressure in rotation		static max. pressure	
	inch	mm	in	mm	in	mm	in	mm	in	mm	in	mm	in	bar	psi	bar	psi	
SJ90-04	1/4"	50	1,97	69	2,72	6	0,24	33,5	1,32	11	0,43	19	0,75	200	2900	400	5800	
SJ90-06	3/8"	54	2,13	76	2,99	8,5	0,33	37,5	1,48	13	0,51	24	0,94	200	2900	400	5800	
SJ90-08	1/2"	63	2,48	87	3,43	11,5	0,45	39,5	1,56	14	0,55	27	1,06	150	2175	300	4350	
SJ90-12	3/4"	74	2,91	104	4,09	15	0,59	54,5	2,15	19,5	0,77	34	1,34	150	2175	300	4350	
SJ90-16	1"	87	3,43	119	4,69	20	0,79	55/60	2,17/2,36	24	0,94	41	1,61	100	1450	300	4350	
SJ90-20	1.1/4"	119,5	4,70	-	-	52	2,05	28	1,10	-	-	50	1,97	100	1450	300	4350	
SJ90-24	1.1/2"	140	5,51	-	-	62	2,44	35	1,38	-	-	55	2,17	80	1160	300	4350	
SJ90-32	2"	151	5,94	-	-	64	2,52	44	1,73	-	-	65	2,56	50	725	250	3625	

MAIN DATA

- Only for occasional rotations;
- Not suitable for continuous or fast rotation;
- Standard seals in nitril rubber;
- Working temperatures with standard seals:
-20 °C / +110 °C;
- Standard thread: BSP (GAS);
- Applications: mounted between a hose and a rigid component compensates for occasional rotation, preventing damage to the hose.

On request

- Special materials: AISI 303, AISI 316, Brass;
- Special seals: Viton, EPDM, Silicone;
- Special thread: NPTF, Metric, UNF.

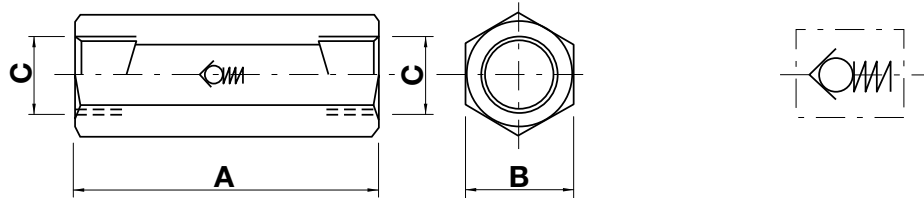
In line check valve.....
QUICK R. COUPLING.....
SWIVEL JOINT.....
HYDRAULIC VALVE

code	Ø C*	maximum flow l/min	maximum pressure		A		B	
	inch		bar	psi	mm	in	mm	in
CV-04	1/4"	13	350	5000	60	2,36	19	0,75
CV-06	3/8"	25	350	5000	70	2,76	24	0,94
CV-08	1/2"	40	350	5000	76	2,99	30	1,18
CV-12	3/4"	60	300	4300	92	3,62	36	1,42
CV-16	1"	90	250	3600	108	4,25	45	1,77
CV-20	1.1/4"	160	250	3600	127	5,00	55	2,17
CV-24	1.1/2"	210	250	3600	142	5,59	65	2,56

* standard thread is BSP (GAS); available thread on request: metric, NPTF, SAE and UNF

VPCC

HYDR. VALVE

Burst hose valve

QUICK R. COUPLING

SWIVEL JOINT

HYDRAULIC VALVE

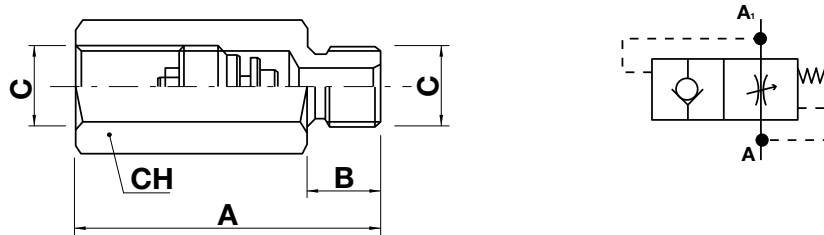

code	Ø C*	A		B		CH	
	inch	mm	in	mm	in	mm	in
VPCC-04	1/4"	53	2,09	13	0,51	19	0,75
VPCC-06	3/8"	55	2,17	13	0,51	22	0,87
VPCC-08	1/2"	64	2,52	14	0,55	27	1,06
VPCC-12	3/4"	67	2,64	15	0,59	36	1,42

* standard thread is BSP (GAS); available thread on request: metric, NPTF, SAE and UNF

CVP

Burst hose cartridge valve

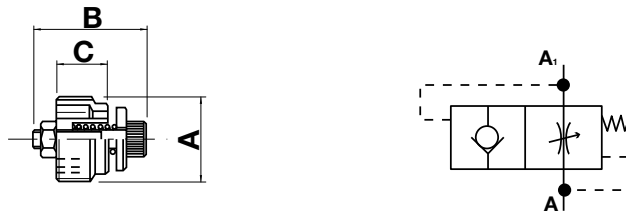

QUICK R. COUPLING

SWIVEL JOINT

HYDRAULIC VALVE

code	Ø A*	B		C	
	inch	mm	in	mm	in
CVP-04	1/4"	19	0,75	8	0,31
CVP-06	3/8"	23	0,91	10,5	0,41
CVP-08	1/2"	29	1,14	13	0,51
CVP-12	3/4"	34	1,34	18	0,71

* standard thread is BSP (GAS); available thread on request: metric, NPTF, SAE and UNF

VRX

HYDR. VALVE

Unidirectional flow regulator

QUICK R. COUPLING

SWIVEL JOINT

HYDRAULIC VALVE

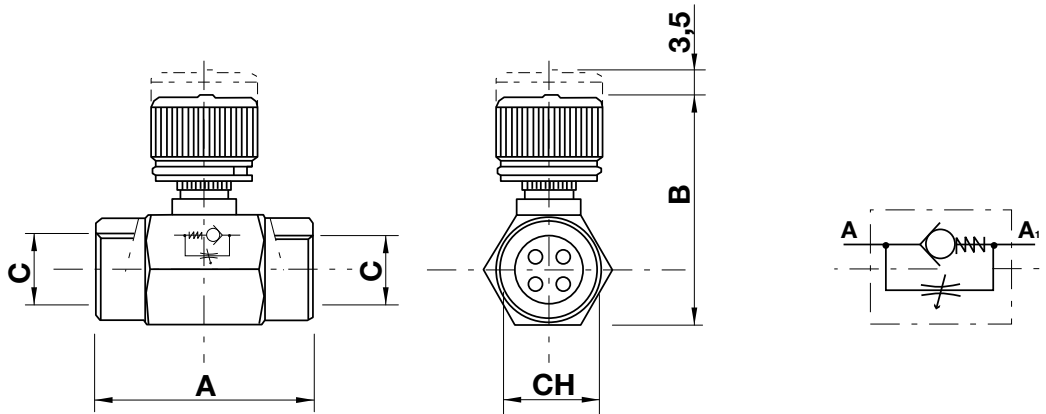

code	Ø C*	maximum flow l/min	maximum pressure		A		B	
	inch		bar	psi	mm	in	mm	in
VRX-04	1/4"	12	300	4350	54	2,13	64	2,52
VRX-06	3/8"	25	300	4350	62	2,44	64	2,52
VRX-08	1/2"	40	280	4000	62	2,44	64	2,52

* standard thread is BSP (GAS); available thread on request: metric, NPTF, SAE and UNF

VRU

Unidirectional flow regulator

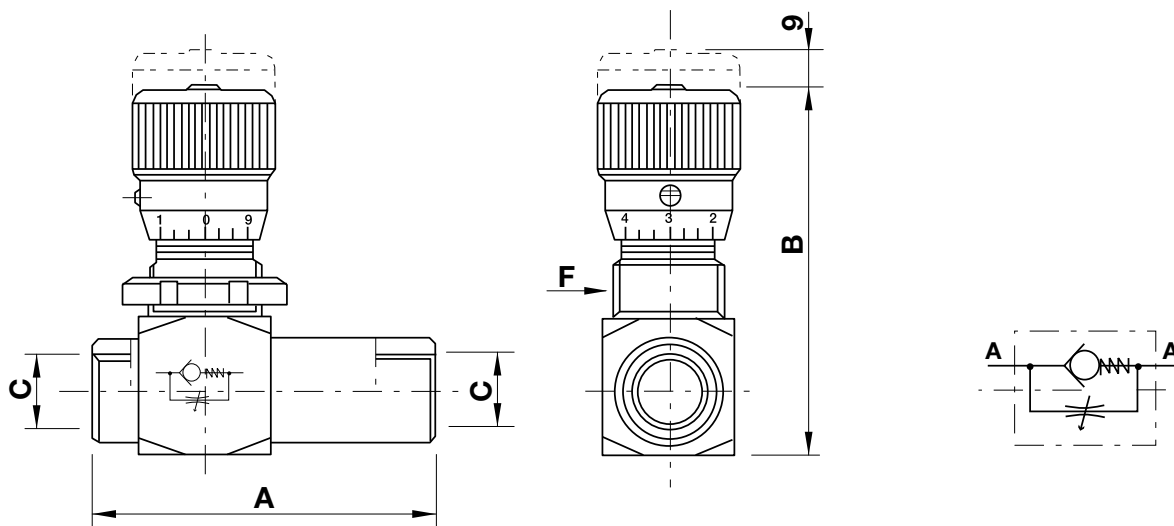

QUICK R. COUPLING

SWIVEL JOINT

HYDRAULIC VALVE

code	Ø C*	maximum flow l/min	maximum pressure		A		B		F
	inch		bar	psi	mm	in	mm	in	
VRU-04	1/4"	12	350	5000	72	2,83	80	3,15	M20X1
VRU-06	3/8"	30	350	5000	78	3,07	85	3,35	M25X1,5
VRU-08	1/2"	45	350	5000	92	3,62	92	3,62	M30X1,5
VRU-12	3/4"	85	300	4350	106	4,17	105	4,13	M35X1,5

* standard thread is BSP (GAS); available thread on request: metric, NPTF, SAE and UNF

VRB

HYDR. VALVE

Bidirectional flow regulator

QUICK R. COUPLING

SWIVEL JOINT

HYDRAULIC VALVE

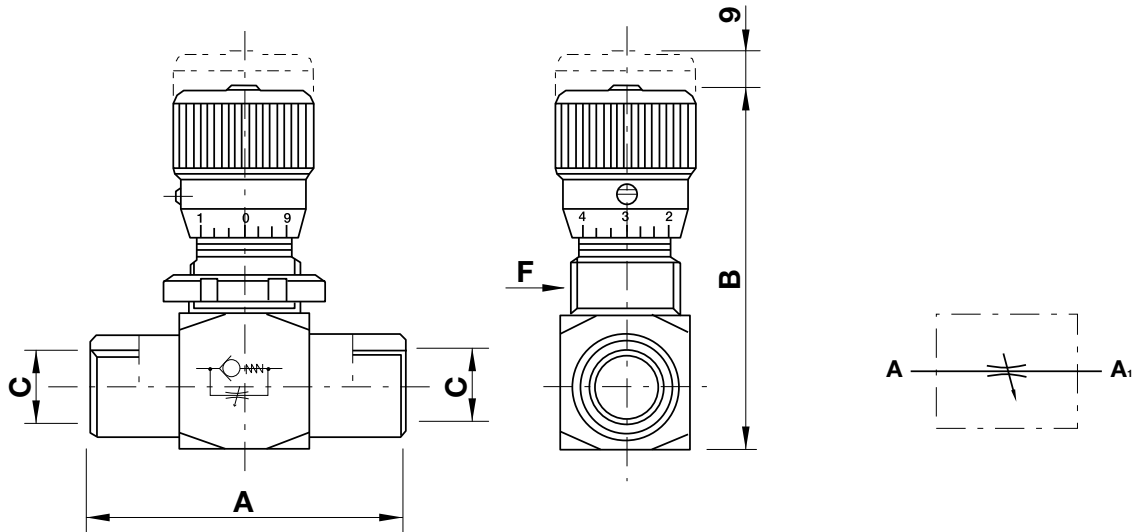

code	Ø C*	maximum flow l/min	maximum pressure		A		B		F
	inch		bar	psi	mm	in	mm	in	
VRB-04	1/4"	12	350	5000	45	1,77	80	3,15	M20X1
VRB-06	3/8"	30	350	5000	52	2,05	85	3,35	M25X1,5
VRB-08	1/2"	45	350	5000	60	2,36	92	3,62	M30X1,5
VRB-12	3/4"	85	300	4350	68	2,68	105	4,13	M35X1,5

* standard thread is BSP (GAS); available thread on request: metric, NPTF, SAE and UNF



GENERAL SALES CONDITIONS

Art. 1 - SCOPE

1.1 - These General Conditions govern all present and future sales contracts entered into by the Seller with regard to its Products, except for any exceptions specifically agreed upon in writing. These General Conditions apply both to contracts with Parties established in Italy and to contracts with Parties established in different States. Any reference to the terms of trade shall be understood to be made to the INCOTERMS 2020 of the International Chamber of Commerce.

1.2 - These General Conditions cancel and replace any other clause and/or General Purchase Conditions attached or otherwise indicated in the orders and/or in the different documentation sent by the Buyer, unless expressly accepted in writing by the Seller. In the latter case as well, unless expressly waived in writing between the Parties, the other clause and/or General Purchase Conditions shall be coordinated with these General Conditions that, insofar as they are compatible, shall remain valid and effective between the Parties.

Art. 2 - FORMATION OF SALES CONTRACT

2.1 - The acceptance by the Buyer of the Seller's offer or order confirmation, howsoever made, entails the application of these General Conditions to the sales contract, even when acceptance takes place by means of execution of the contract. The Seller's offer shall be deemed firm and irrevocable only when it is qualified as such in writing by the Seller and a term of validity is specified therein. The Buyer's reply containing supplements or amendments, even if such as not to substantially alter the terms of the Supplier's proposal shall be deemed as a counterproposal, notwithstanding the Seller's silence. Any offers made by agents, representatives and/or sales assistants of the Seller shall not be binding for the Seller until confirmed by it.

Art. 3 - SAMPLES, DRAWINGS AND TECHNICAL DOCUMENTS - SUBCONTRACTING - CONFIDENTIALITY

3.1 - The weights, dimensions, thicknesses, capacities, prices, yields, colours and other data contained in the Seller's catalogues, brochures, advertisements, illustrations, price lists or other documents, as well as the characteristics of the samples and models sent by the latter to the Buyer, are to be considered purely indicative and, therefore, they are not binding, unless expressly mentioned as such in the Seller's offer or order confirmation.

3.2 - Any drawing, document, technical information or software which permits the manufacture or assembly of the sold Products or parts thereof which are delivered to the Buyer, both before and after the conclusion of the contract, remain the sole property of the Seller. The above-mentioned drawings, documents, technical information or software may not be used by the Buyer for non-contractual purposes as well as copied, reproduced, sent or communicated to third parties without the prior written consent of the Seller. The Buyer, in particular, may not entrust to third parties, nor carry out directly, the manufacture of Products which are a total or partial reproduction of the Products or which in any case use intellectual property rights, know-how or technology of the Seller.

3.3 - The Buyer's drawings, documents, technical information or software delivered to the Seller before or after the conclusion of the contract, shall remain the sole property of the Buyer and shall not be used by the Seller, or copied, reproduced, sent or communicated to third parties without the written consent of the Buyer to the extent that they are:

- a) covered by a patent or other industrial or intellectual property right of the Buyer; or
- b) secret, i.e. they do not refer to knowledge made public by

the Buyer or otherwise known to the generality of the operators in the sector, and are not trivial; provided, however, that the Buyer has expressly made known to the Seller in writing its desire to reserve for itself the exclusive right of exploitation.

3.4 - The Seller reserves the right, under its own responsibility, to subcontract part of the Products ordered by the Buyer.

3.5 - The Buyer undertakes not to disclose to third parties or to use for non-contractual purposes, even after the termination of any agreement with the Seller, any commercial or business secrets, as well as any confidential information of the Seller, that it became aware during the contractual relationship.

Art. 4 - PRODUCT DELIVERY

4.1 - Unless otherwise agreed, the delivery of Products shall take place Ex works (INCOTERMS 2020), even when the Parties have agreed that shipment and/or assembly shall be carried out by the Seller. In this case, the Seller shall act as the Buyer's agent, it being understood that transport shall be carried out by the Buyer at its own expense and risk.

4.2 - The risks shall pass to the Buyer according to the applicable INCOTERMS. In no case, the Seller shall be liable for the deterioration or damage of the Products occur after the passing of risks and the Buyer shall in any case be obliged to pay the agreed price.

4.3 - The Seller shall make its best efforts to comply with the delivery terms indicated in the offer or in the order confirmation, which, unless otherwise agreed in writing between the Parties, cannot be regarded as essential.

4.4 - Should the Parties have agreed to the payment of a penalty by the Seller in case of delay in the delivery of the Products, the Buyer shall not be entitled to claim, as compensation for damages caused by the delay, the payment of amounts in addition to those agreed as a penalty.

4.5 - The delivery terms shall be understood as extended by a period equal to the duration of the impediment if the Buyer does not provide - in due time - the data or materials necessary for the supply, requests variations in progress or is late in responding to requests for approval of the drawings or the executive diagrams.

4.6 - The Buyer shall always held to take delivery of the Products, even in the case of partial deliveries, early deliveries, or deliveries carry out after the date agreed by the Parties. Under no circumstances, the Seller shall be liable for direct and/or indirect damage deriving from early or delayed delivery of the Products. Should the Buyer not take delivery of the Products for reasons not attributable to the Seller or for force majeure reasons, the Buyer shall support all the expenses that may derive therefrom, and any sum due to the Seller, at any time, will become immediately due.

In this case the Seller may:

- a) put in stock the Products at the risk, danger and expense of the Buyer; or
 - b) send the Products in the name, on the behalf of and at the Buyer's expense to the Buyer's premises; or
 - c) sell the Products by any means on behalf of the Buyer, withholding from the proceeds the whole sum due, as well as the expenses incurred.
- Eventual further damages not excluded.

Art. 5 - WARRANTY

5.1 - The Seller warrants that the supplied Products comply in terms of quantity, quality, type as well as to technical specifications expressly agreed in the contract, excluding any warranty regarding the specific use which the Buyer, or its sub-buyer, makes of the purchased product. Moreover, the Seller warrants that the Products are free from defects that may make them unsuitable for their intended use.

5.2 - The warranty shall be limited to defects of the Products

resulting from defects in material or manufacturing attributable to the Seller and shall not be valid if:

- a) the Buyer fails to prove that the Products have been properly used, maintained, stored and looked after;
- b) the Buyer has made changes or repairs to the Products without the prior written consent of the Seller;
- c) the Products have been assembled or used incorrectly;
- d) Product defects are due to normal wear and tear of those parts which, by their nature, are subject to rapid and continuous wear and tear;
- e) the conformity defects were caused by an event subsequent to the transfer of risks to the Buyer.

5.3 - The warranty lasts for 12 (twelve) months starting from the date of delivery of the Products to the Buyer. The warranty is subject to regular and timely notification of defects and nonconformities by the Buyer according to the provisions of the following paragraph, as well as express written warranty service request. The warranty for replaced Products shall become effective from the day of any replacement. The warranty for the replaced components of the Product shall begin on the day of replacement, and in any case applies only to the replaced component.

5.4 - The Buyer shall notify Products defects or nonconformities in writing, indicating in detail the detected defects and nonconformities, the date of delivery and the quantity of defective Products. The notification must be made, under penalty of forfeiture, within and not later than 15 days from the date of delivery in the case of obvious defects or from the date of discovery, provided that it is made within the warranty period, in the case of hidden faults, defects or nonconformities.

5.5 - The Buyer shall forfeit the warranty if it fails to agree any reasonable check requested by the Seller or if, the Seller offers to replace the fault part at its own expense, the Buyer fails to return the defective Products within 15 days from the request.

5.6 - Should the Buyer's complaint is unfounded, the Buyer shall be obliged to reimburse the Seller for all expenses incurred by the latter for the inspection. Instead, should the Buyer's complaint, made in accordance with the provisions of this article, is well-founded, the Seller shall, in its sole discretion and within a reasonable time (having regard to the seriousness of the complaint), replace free of charge defective or nonconforming Products at the Seller's premises. The Buyer shall be responsible for returning the Products. Should the Parties agree that the replacement operations are best carried out directly at the Buyer's premises or elsewhere, the travel expenses - including travel, board and lodging of the Seller's personnel - shall be to the charge of the Buyer, who shall also provide all means and auxiliary personnel required to do the job in the fastest and safest way.

5.7 - Once the warranty period has elapsed, no claim may be made against the Seller.

Art. 6 - LIMITED LIABILITY OF SELLER

6.1 - Except in case of fraud or gross negligence on the part of the Seller, any compensation for any damage to the Buyer shall not in any case exceed the invoice value of the defective Product. The warranty referred to in the previous Article includes and supersedes all legal warranties for defects and conformity, excluding any other possible liability of the Seller, howsoever deriving from the supplied Products. The Buyer shall therefore not be entitled to lodge any other claims for damages, price reduction or contract termination.

6.2 - The Seller's liability is contained within the limits set forth in the previous Article and relates only to the Products supplied by the Seller itself. The latter therefore disclaims all liability for any failure or malfunction of systems or machines manufactured by the Buyer or by third parties using the Products supplied by the Seller, even in the event of these hav-

ing been assembled or connected according to diagrams or drawings suggested by the Seller, unless such diagrams and drawings have been the subject of separate remuneration: in the latter case, the Seller's liability shall in any case be limited to what is included in the diagrams or drawings in question.

6.3 - Under no circumstances shall the Seller be deemed liable for indirect or consequential damages, loss of production or lost profits.

Art. 7 - TECHNICAL STANDARDS AND CIVIL LIABILITY

7.1 - The Seller warrants the performance of the Products only and exclusively in relation to the uses, purposes, applications, tolerances, capacities expressly indicated by it and the Buyer is not therefore authorised to make use of them in a different way. If the Buyer's intention is to resell the Products, the Buyer shall be required to bring and shall be responsible for bringing to the knowledge of its buyers the indications set forth in the previous paragraph.

7.2 - The compensation for any personal injury or property damage, caused by defects in the supplied Products and directly attributable to the Seller, shall be limited to the maximum amount indicated in the policy for third party liability and is subject to the terms and conditions of application of said policy.

Art. 8 - PRICES - PAYMENTS

8.1 - Unless otherwise specified in the offer or order confirmation, prices should be understood as Ex Works and, do not include: packaging costs, taxes, duties, and any other additional charges. Likewise, unless otherwise agreed by the Parties, the following are not included in the price: any design and installation of the supplied Products, tests, manuals and training courses, start-up assistance, and all services and charges not mentioned in the offer or order confirmation.

8.2 - Payments, and any other sum due to the Seller for any reason whatsoever, shall be deemed to be net at the Seller's registered office and shall be made in accordance with the agreed terms and conditions. The Buyer, in case of delay in payment, shall be required to pay default interest, without the need for notice of default.

8.3 - Any delay in payment shall also give the Seller the right to invalidate, for the entire duration of the delay, the warranty referred to in Art. 5 above. The Buyer shall be obliged to pay the full price even in case of dispute or complaint. No offset-

ting shall be allowed against any amounts owed, howsoever arising, by the Seller.

Art. 9 – RETENTION OF TITLE

9.1 - In the event of payment being made - in whole or in part - after delivery, the delivered Products remain the Seller's property until the moment of the complete payment of the price according to the measure allowed by the law of the country where the Products are located. The Buyer undertakes to do whatever necessary to constitute in the country above mentioned a valid retention of title in the most extensive form permitted, or to provide a similar form of guarantee in favour of the Seller.

Art. 10 - WITHDRAWAL FROM SALES CONTRACT - SUSPENSION

10.1 - The Seller reserves the right to withdraw from the sales contract and cancel, in whole or in part, the Buyer's order in the event of a significant change in the Buyer's economic conditions and solvency, as well as in the case of any payment delay or irregularity on the part of the Buyer, including if related to a different supply.

10.2 - The Seller shall be entitled at any time to suspend the execution of the contract, giving written notice of at least 30 (thirty) working days to the Buyer for a maximum of 3 (three) months without incurring any liability. Within 3 (three) months from the relative notice of suspension, the Seller shall be required to communicate to the Buyer the continuation of the contract execution with prior written notice of at least 30 (thirty) working days. In the event of the Seller not asking for the contract to be continued within the established time limit of 3 (three) months, the Buyer shall be entitled to terminate the contract immediately by giving prompt written notice to the Seller.

Art. 11 - FORCE MAJEURE

11.1 - Should the manufacture and/or delivery of the Products by the Seller become impossible, excessively onerous or delayed due to a Force Majeure Event as defined in paragraph 11.2 below, the Seller may, at its option: (i) suspend deliveries of the Products until the Force Majeure Event has ceased; (ii) deliver a smaller quantity of Products, if the Products in its warehouse are insufficient and intended proportionately to satisfy other customers of the Seller; (iii) withdraw from the

contract, giving prompt written notice to the Buyer. Following the withdrawal, the Seller shall complete the execution of the delivery of the Products purchased by the Buyer for the part not affected by the Force Majeure Event, it being understood that the Buyer shall not make any further claim against the Seller, deriving directly or indirectly from the early termination of the contractual agreement.

If the impediment caused by the Force Majeure Event persists for a period of more than 90 (ninety) days, each party shall be entitled to withdraw from the relevant contract, without its acquiring any right to compensation for damages with respect to the other party.

Should any Force Majeure Event occur, the Seller shall not in any case be liable for any damages suffered by the Buyer as a result of the delay in delivery of the Products.

11.2 - "Force Majeure Event" means any event beyond the Seller's control that affects the production or delivery capacity of the Products - including without limitation strikes, non-delivery or delayed delivery, including partial, of raw materials by the Seller's suppliers, partial or total breakdowns of machinery and plants to be used in the production of the Products, fires, floods, riots, government decisions, regulatory changes, epidemics, pandemics or other health emergencies.

Art. 12 – APPLICABLE LAW - DISPUTES

12.1 - For everything not provided for, these general conditions shall be governed by Italian law. Any dispute arising out or in connection with the contracts to which these General Conditions apply shall be subject to the exclusive jurisdiction of the Seller's Court of Law. However, the Seller shall be entitled to act before Court of Law where the Buyer's registered office is located.

According to and for the effects of articles 1341 and 1342 of the Italian Civil Code, the following articles are deemed expressly approved: Art. 4.6 - Buyer's obligation to take over the Products - Limitation of the Seller's liability in case of delayed or early delivery of the Products; Art. 5.5 - Forfeiture of the right of warranty; Art. 6 - Limited liability of Seller; Art. 7.2 - Civil Liability; Art. 8.3 - Invalidation of warranty due to late payment - Obligation to pay disputed amounts - No set-off; Art. 10 - Withdrawal from sales contract - Suspension; Art. 12 - Applicable law - Disputes.

CONDIZIONI GENERALI DI VENDITA

Art. 1 - AMBITO DI APPLICAZIONE

1.1 - Le presenti Condizioni Generali disciplinano tutti gli attuali e futuri contratti di vendita stipulati dal Venditore relativamente ai suoi Prodotti salvo eventuali deroghe specificamente concordate per iscritto e si applicano sia ai contratti con Parti aventi sede in Italia sia a contratti con Parti che abbiano sede in Stati diversi. Il riferimento ad eventuali termini di resa si intenderà fatto agli INCOTERMS ed. 2020 della Camera di Commercio Internazionale.

1.2 - Le presenti Condizioni Generali annullano e sostituiscono ogni eventuale altra clausola e/o Condizione Generale di Acquisto allegata o altrimenti indicata negli ordini e/o nella diversa documentazione trasmessa dal Compratore, a meno che espressamente accettata per iscritto dal Venditore. Anche in quest'ultimo caso però, salvo espressa deroga scritta tra le Parti, le stesse dovranno essere coordinate con le presenti Condizioni Generali che, in quanto compatibili, rimarranno comunque efficaci tra le Parti.

Art. 2 - FORMAZIONE DEL CONTRATTO DI VENDITA

2.1 - L'accettazione, da parte del Compratore, dell'offerta o della conferma d'ordine del Venditore, comunque effettuata, comporta l'applicazione al contratto di vendita delle presenti Condizioni Generali, e ciò anche quando l'accettazione avvenga mediante la semplice esecuzione del contratto. L'offerta del Venditore si considera ferma ed è irrevocabile soltanto se viene dallo stesso qualificata tale per iscritto ed è in essa specificato un termine di validità. Si considera controproposta, nonostante il silenzio del Venditore, la risposta del Compratore che contenga aggiunte o modifiche, anche se tali da non alterare sostanzialmente i termini della proposta. Eventuali offerte fatte da agenti, rappresentanti e/o ausiliari di commercio del Venditore non saranno impegnative per quest'ultimo fino alla conferma da parte del Venditore stesso.

Art. 3 - CAMPIONI, DISEGNI E DOCUMENTI TECNICI - SUBFORNITURA - RISERVATEZZA

3.1 - I pesi, le dimensioni, gli spessori, le capacità, i prezzi, i rendimenti, i colori e gli altri dati figuranti nei cataloghi, prospetti, annunci pubblicitari, illustrazioni, listini prezzi o altri documenti del Venditore, così come le caratteristiche dei campioni e dei modelli da quest'ultimo inviati al Compratore, hanno carattere di indicazioni approssimative e, pertanto, non hanno valore impegnativo se non nella misura in cui espressamente menzionati come tali nell'offerta o nella conferma d'ordine del Venditore.

3.2 - Qualsiasi disegno, documento, informazione tecnica o software che permetta la fabbricazione o il montaggio dei Prodotti venduti o di loro parti del Venditore che siano rimessi al Compratore, tanto prima che dopo la stipulazione del contratto, rimangono di esclusiva proprietà del Venditore. I suddetti disegni, documenti, informazioni tecniche o software non potranno essere utilizzati dal Compratore per fini extracontrattuali o copiati, riprodotti, trasmessi o comunicati a terzi senza il previo consenso scritto del Venditore. Il Compratore, in particolare, non potrà affidare a terzi, né effettuare direttamente, la realizzazione di Prodotti che siano una riproduzione, totale o parziale, dei Prodotti o che comunque impieghino diritti di proprietà intellettuale, know-how o tecnologia del Venditore.

3.3 - I disegni, documenti, informazione tecnica o software del Compratore rimesse al Venditore prima o dopo la stipula del contratto, rimangono di esclusiva titolarità del Compratore e non potranno essere utilizzati dal Venditore, o copiati, riprodotti, trasmessi o comunicati a terzi senza il consenso scritto del Compratore nei limiti in cui essi:

a) siano coperti da brevetto o ad un altro diritto di proprietà

industriale o intellettuale del Compratore; ovvero

b) abbiano carattere segreto, e cioè non si riferiscano a cognizioni rese pubbliche dal Compratore o altrimenti note alla generalità degli operatori del settore, e non siano banali; purché, tuttavia, il Compratore abbia espressamente manifestato al Venditore per iscritto la propria volontà di riservarsi il diritto di sfruttamento esclusivo.

3.4 - Il Venditore si riserva il diritto, sotto la propria responsabilità, di affidare in subfornitura parte dei Prodotti commissionatigli dal Compratore.

3.5 - Il Compratore si impegna a non rivelare a terzi né ad utilizzare a fini extracontrattuali, anche dopo la cessazione di ogni rapporto con il Venditore, i segreti commerciali od aziendali, nonché ogni notizia riservata del Venditore di cui sia venuto a conoscenza in occasione dei rapporti contrattuali instaurati con quest'ultimo.

Art. 4 - CONSEGNA DEI PRODOTTI

4.1 - Salvo patto contrario, la consegna dei Prodotti ha luogo Ex works (INCOTERMS 2020), anche quando le Parti abbiano convenuto che la spedizione e/o il montaggio avvengano a cura dal Venditore: in tal caso, infatti, il Venditore agirà come mandatario del Compratore, essendo inteso che il trasporto verrà effettuato a spese e a rischio di quest'ultimo.

4.2 - I rischi passano al Compratore secondo quanto stabilito negli INCOTERMS applicabili. Il Venditore non risponde in nessun caso del perimento o del danneggiamento dei Prodotti avvenuto dopo il passaggio dei rischi ed il Compratore sarà comunque tenuto al pagamento del prezzo pattuito.

4.3 - Il Venditore farà del suo meglio per rispettare i termini di consegna indicati nell'offerta ovvero nella conferma d'ordine che comunque, salvo diverso accordo scritto tra le Parti, non potranno essere considerati essenziali.

4.4 - Laddove le Parti abbiano convenuto il pagamento di una penale da parte del Venditore per il caso di ritardo nella consegna dei Prodotti, il Compratore non potrà esigere, a titolo di risarcimento dei danni causati dal ritardo, il pagamento di somme ulteriori rispetto a quelle pattuite a titolo di penale.

4.5 - I termini di consegna dovranno intendersi prorogati di un periodo pari a quello di durata dell'impedimento qualora il Compratore non fornisca in tempo utile i dati o i materiali necessari alla fornitura, richieda delle varianti in corso di esecuzione ovvero ritardi nel rispondere alle richieste di approvazione dei disegni o degli schemi esecutivi.

4.6 - Il Compratore è sempre tenuto a prendere in consegna i Prodotti anche in caso di consegne parziali, anticipate o successive alla data concordata dalle Parti. In nessun caso il Venditore potrà essere ritenuto responsabile per i danni diretti e/o indiretti derivanti da anticipata o ritardata consegna dei Prodotti. Nel caso in cui il Compratore non abbia preso in consegna i Prodotti per cause non imputabili al Venditore o per cause di forza maggiore, il Compratore sopporterà tutte le spese, e ogni somma dovuta al Venditore, a qualsiasi titolo, diventerà immediatamente esigibile.

In tal caso il Venditore potrà:

a) immagazzinare i Prodotti a rischio, pericolo e spese del Compratore;

b) spedire i Prodotti in nome, per conto e a spese del Compratore presso la sede di quest'ultimo;

c) vendere con qualsiasi mezzo i Prodotti per conto del Compratore, trattenendo dal ricavato l'intero importo dovuto nonché le spese sostenute.

Sono fatti salvi gli ulteriori danni.

Art. 5 - GARANZIA

5.1 - Il Venditore garantisce che i Prodotti forniti sono conformi per quantità, qualità, tipo nonché alle specifiche tecniche espressamente concordate in contratto, con esclusione di qualunque garanzia circa l'impiego specifico al quale il Compratore, o il suo sub-acquirente, destina il prodotto acquista-

to, e che sono esenti da vizi che possano renderli non idonei all'uso cui sono destinati.

5.2 - La garanzia per vizi è limitata ai soli difetti dei Prodotti conseguenti a difetti di materiale o di fabbricazione riconducibili al Venditore e non opera nel caso in cui:

a) il Compratore non provi di aver effettuato un corretto uso, manutenzione, stoccaggio e conservazione dei Prodotti;

b) il Compratore abbia apportato delle modifiche o riparazioni ai Prodotti, senza il previo consenso scritto del Venditore;

c) i Prodotti siano stati montati o utilizzati non correttamente;

d) i difetti dei Prodotti siano dovuti alla normale usura di quelle parti che, per loro natura, sono soggette ad usura rapida e continua;

e) i difetti di conformità abbiano la loro causa in un fatto successivo al passaggio dei rischi al Compratore.

5.3 - La garanzia ha una durata di 12 (dodici) mesi decorrenti dalla data della consegna dei Prodotti al Compratore ed è subordinata alla regolare e tempestiva denuncia dei vizi e delle difformità da parte di quest'ultimo secondo quanto disposto al successivo comma, accompagnata dall'espressa richiesta scritta al Venditore di effettuare un intervento in garanzia. La garanzia per i Prodotti sostituiti decorre dal giorno dell'eventuale sostituzione. La garanzia per i componenti del Prodotto sostituiti decorre dal giorno dell'eventuale sostituzione, e comunque vale per il solo componente sostituito.

5.4 - La denuncia dei vizi o difetti di conformità dei Prodotti deve essere effettuata dal Compratore per iscritto e indicare dettagliatamente i vizi e le non conformità contestate, la data della consegna e la quantità di Prodotti difettosi. La denuncia deve essere effettuata, a pena di decadenza vizi e non oltre 15 giorni decorrenti dalla data di consegna, nel caso di vizi palesi ovvero dalla data della scoperta, purché entro il periodo di durata della garanzia, laddove si tratti di vizi, difetti o non conformità occulti.

5.5 - Il Compratore decade dal diritto di garanzia laddove non consenta ogni ragionevole controllo richiesto dal Venditore o se, avendo il Venditore fatto richiesta di restituzione del Prodotto difettoso a proprie spese, il Compratore ometta di restituire i Prodotti difettosi entro 15 giorni dalla richiesta.

5.6 - Nel caso in cui la denuncia effettuata dal Compratore risulti infondata, quest'ultimo sarà tenuto a risarcire al Venditore tutte le spese da quest'ultimo sostenute per l'accertamento. Qualora invece la denuncia del Compratore, effettuata in conformità a quanto statuito nel presente articolo, risulti fondata, il Venditore provvederà - a sua esclusiva e discrezionale scelta ed entro un termine ragionevole (avuto riguardo all'entità della contestazione) - a sostituire gratuitamente EXW-sede del Venditore i Prodotti difettosi o non conformi, effettuando le suddette operazioni presso i propri stabilimenti. La resa dei Prodotti è a carico del Compratore. Laddove le Parti concordino sull'opportunità di effettuare le operazioni di sostituzione direttamente presso gli stabilimenti del Compratore o in altro luogo, le spese di trasferta - comprendenti viaggio, vitto e alloggio del personale del Venditore - saranno a carico del Compratore, il quale fornirà inoltre tutti i mezzi e il personale ausiliario richiesti per eseguire l'intervento nel modo più rapido e sicuro.

5.7 - Decorsa la durata della garanzia, nessuna pretesa potrà essere fatta valere nei confronti del Venditore.

Art. 6 - LIMITAZIONE DI RESPONSABILITÀ DEL VENDITORE

6.1 - Salvo dolo o colpa grave del Venditore, l'eventuale risarcimento di qualsiasi danno al Compratore non potrà comunque superare il valore di fattura del Prodotto difettoso. La garanzia di cui al precedente Articolo è assorbente e sostitutiva delle garanzie legali per vizi e conformità ed esclude ogni altra possibile responsabilità del Venditore, comunque originata dai Prodotti forniti. Il Compratore non potrà pertanto avanzare altre richieste di risarcimento del danno, di ridu-

zione del prezzo o di risoluzione del contratto.

6.2 - La responsabilità del Venditore è contenuta nei limiti di cui al precedente Articolo ed è relativa ai soli Prodotti forniti dal Venditore medesimo. Quest'ultimo non assume pertanto alcuna responsabilità per l'eventuale difettoso funzionamento di sistemi o macchine realizzati dal Compratore o da terzi con i Prodotti forniti dal Venditore, anche nel caso gli stessi siano stati montati o collegati secondo schemi o disegni suggeriti dal Venditore, a meno che tali schemi e disegni non siano stati oggetto di distinta remunerazione: in tale ultimo caso, la responsabilità del Venditore sarà comunque circoscritta a quanto compreso negli schemi o disegni in oggetto.

6.3 - In nessun caso il Venditore potrà essere ritenuto responsabile per danni indiretti o consequenziali, perdite di produzione o mancati profitti.

Art. 7 - NORME TECNICHE E RESPONSABILITÀ CIVILE

7.1 - Il Venditore garantisce le prestazioni dei Prodotti solo ed esclusivamente in relazione ad usi, destinazioni, applicazioni, tolleranze, capacità da lui espressamente indicati e il Compratore non è dunque autorizzato a disporre in modo difforme. Qualora il Compratore destini i Prodotti alla rivendita, sarà suo onere e responsabilità portare a conoscenza dei suoi acquirenti le indicazioni di cui al precedente comma.

7.2 - Il risarcimento per eventuali danni a persone o cose, derivanti dalla difettosità dei Prodotti forniti e direttamente riconducibile al Venditore, è limitato al massimale indicato nella polizza per responsabilità civile della medesima ed è subordinato ai termini ed alle condizioni di applicazione di detta polizza.

Art. 8 - PREZZI - PAGAMENTI

8.1 - Salvo sia altrimenti specificato nell'offerta o nella conferma d'ordine, i prezzi si intendono sempre Ex Works e non comprendono: i costi di imballaggio, le imposte, i dazi e ogni altro onere aggiuntivo. Del pari, a meno che le Parti abbiano diversamente convenuto, non sono compresi nel prezzo: l'eventuale progettazione e l'installazione dei Prodotti forniti, i collaudi, manuali e corsi di addestramento, l'assistenza all'avviamento e tutte le prestazioni e gli oneri non menzionati nell'offerta o nella conferma d'ordine.

8.2 - I pagamenti, e ogni altra somma dovuta a qualsiasi titolo al Venditore, si intendono netti alla sede del Venditore e dovranno essere effettuati conformemente alle modalità convenute. Il Compratore, in caso di ritardo nel pagamento, sarà tenuto a corrispondere, senza necessità di messa in mora, gli interessi moratori.

8.3 - Eventuali ritardi nei pagamenti attribuiranno altresì al

Venditore il diritto di escludere, per tutto il periodo di permanenza del ritardo, la garanzia di cui al precedente Art. 5. Il Compratore è tenuto al pagamento integrale del prezzo anche in caso di contestazione o controversia. Non è ammessa compensazione con eventuali crediti, comunque insorti, nei confronti del Venditore.

Art. 9 - RISERVA DI PROPRIETÀ

9.1 - Nel caso in cui il pagamento debba essere effettuato - in tutto o in parte - dopo la consegna, i Prodotti consegnati restano di proprietà del Venditore sino al momento del completo pagamento del prezzo nella misura permessa dalla legge del Paese dove i prodotti si trovano. Il Compratore s'impegna a fare quanto necessario per costituire nel suddetto Paese una valida riserva di proprietà nella forma più estesa consentita, o per porre in essere un'analoga forma di garanzia a favore del Venditore.

Art. 10 - RECESSO DAL CONTRATTO DI VENDITA - SOSPENSIONE

10.1 - Il Venditore si riserva il diritto di recedere dal contratto di vendita e annullare, in tutto od in parte, l'ordine del Compratore in caso di sensibile modifica delle condizioni economiche del Compratore e della sua solvibilità nonché qualsiasi ritardo o irregolarità nel pagamento da parte del Compratore, anche se relativo a una diversa fornitura.

10.2 - Il Venditore potrà in ogni momento sospendere l'esecuzione del contratto, dandone preavviso scritto di almeno 30 (trenta) giorni lavorativi al Compratore per un massimo di 3 (tre) mesi senza incorrere in alcuna responsabilità. Entro 3 (tre) mesi dalla relativa comunicazione di sospensione il Venditore dovrà comunicare al Compratore la ripresa dell'esecuzione del contratto dandone preavviso scritto di almeno 30 (trenta) giorni lavorativi. Qualora il Venditore non richieda la prosecuzione del contratto entro il termine stabilito di 3 (tre) mesi, il Compratore avrà la facoltà di risolvere immediatamente il contratto dandone tempestiva comunicazione scritta al Venditore.

Art. 11 - FORZA MAGGIORE

11.1 - Ove la produzione e/o la consegna dei Prodotti da parte del Venditore sia resa impossibile, eccessivamente onerosa o ritardata a causa di un Evento di Forza Maggiore come definito dal successivo Art. 11.2, il Venditore potrà, a propria scelta: (i) sospendere le consegne dei Prodotti fintantoché non sia cessato l'Evento di Forza Maggiore; (ii) consegnare una quantità minore di Prodotti, qualora i Prodotti presenti nel proprio

magazzino siano insufficienti e vengano destinati in proporzione a soddisfare altri clienti del Venditore; (iii) recedere dal contratto, dandone tempestiva notifica per iscritto al Compratore. A seguito del recesso, il Venditore completerà l'esecuzione della consegna dei Prodotti acquistati dal Compratore per la parte non inficiata dall'Evento di Forza Maggiore, restando inteso che il Compratore non avanzerà qualsivoglia ulteriore pretesa nei confronti del Venditore, derivante direttamente o indirettamente dall'anticipato scioglimento del rapporto contrattuale.

Ove l'impedimento dovuto all'Evento di Forza Maggiore persista per un periodo superiore a 90 (novanta) giorni, ciascuna parte avrà diritto di recedere dal relativo contratto, senza che sorga in capo ad essa alcun diritto nei confronti dell'altra parte al risarcimento di danni.

Ove ricorrano Eventi di Forza Maggiore, il Venditore non risponderà in alcun caso di eventuali danni derivanti per il Compratore dal ritardo nella consegna dei Prodotti.

11.2 - Per "Evento di Forza Maggiore" si intende qualsiasi evento al di fuori del controllo del Venditore che incida sulla capacità produttiva o di consegna dei Prodotti - ivi inclusi, a titolo esemplificativo, scioperi, mancata o ritardata consegna, anche parziale, delle materie prime da parte dei fornitori del Venditore, rotture parziali o totali di macchinari e impianti da impiegarsi nella realizzazione dei Prodotti, incendi, inondazioni, rivolte, decisioni delle autorità, modifiche normative, epidemie, pandemie o altre emergenze sanitarie.

Art. 12 - LEGGE APPLICABILE - CONTROVERSIE

12.1 - Per tutto quanto non previsto le presenti Condizioni Generali sono regolate dalla legge italiana. Per ogni controversia relativa o comunque collegata ai contratti cui si applicano le presenti Condizioni Generali è esclusivamente competente il Foro del Venditore. Quest'ultimo avrà tuttavia facoltà di agire dinanzi al foro della sede del Compratore.

Ai sensi e per gli effetti degli articoli 1341 e 1342 del Codice Civile si intendono espressamente approvati i seguenti articoli: Art. 4.6 - Obbligo del compratore di prendere in consegna i Prodotti - Limitazione di responsabilità del Venditore in caso di consegna ritardata o anticipata dei Prodotti; Art. 5.5 - Decadenza dal diritto di garanzia; Art. 6 - Limitazione di responsabilità del Venditore; Art. 7.2 - Responsabilità Civile; Art. 8.3 - Esclusione di garanzia per ritardo nel pagamento - Obbligo di pagamento somme contestate - Divieto di Compensazione; Art. 10 - Recesso dal contratto di vendita - Sospensione; Art. 12 - Legge applicabile - Controversie.







This catalogue is printed
on FSC certified paper.

Save paper, save trees!
Please note you will always
find the most updated edition
of this catalogue available on
our website **www.intertraco.it**

Intertraco (Italia) S.p.A.

Via Amaldi 1/A
I-46029 Suzzara
Mantova | Italy

T +39 0376 539711
F +39 0376 521722
info@intertraco.it

www.intertraco.it

